

## **RE: First Reading Council Bill 2024-40 Authorizing a Pole Attachment Agreement with Total Highspeed, LLC.**

### **Background:**

This Council Bill proposes the approval of a Pole Attachment Agreement with Total Highspeed, LLC., and authorizes the City Administrator to execute it on behalf of the City.

### **Analysis:**

Total Highspeed representatives approached staff with a desire to enter into a pole attachment agreement to give them the authorization to utilize our above ground electric infrastructure for the installation of fiber.

Staff already has a generic Pole Attachment Agreement developed by the Missouri Public Utility Alliance and their legal consultants, Healy Law, which is used by a number of the municipal utilities as a standard. This serves not only to assist hometown utilities like Nixa with agreement development, it does that so it fits within the regulatory rules, specifically the Federal Communications Commission (FCC). An added bonus is that all communication companies across the state who wish to have pole attachments in our communities know the basic standards that will be required from town to town.

The pole attachment agreement before you comes from the forementioned boilerplate version, this same pole attachment agreement was utilized with Ozark Fiber earlier this year to also enter into an agreement for fiber installation.

As an overview, the agreement sets certain standards to protect our infrastructure while still allowing for the service with minimal added infrastructure. The agreement sets forth pole attachment rates to be charged annually as well as how to handle various situations such as who is responsible to upgrade a pole to accommodate the new facility. This is generally stated because there are many variations in how the standards are used. The agreement also covers permits for each installation as well as construction standards, inspecting and mapping of the third-party system.

Nixa already has fees and/or formulas for fees in place which include a Right-of-Way Encroachment Permit to cover work in the right of way as well as an annual pole rental formula developed to meet FCC rules. Though the encroachment permit fee is set for an indefinite period, the annual pole attachment rate is based on an FCC approved formula and can be updated each year.

We currently charge \$100 for an encroachment permit; these can cover an area (usually for underground utilities) or a certain limited number of poles also within a reasonable area. As example, a company can apply for a permit for 10 or so poles along an area where they are reasonably connected but can't make one application for multiple poles in various places around town.

The formula for our pole attachment rate is set to meet FCC rules and can be updated annually to account for the rising cost of materials. The formula is based on the use of a

certain part of a pole and not just a random number or total cost recovery for a pole. Our current annual pole rate per attachment is \$11.14.

Another cost Total Highspeed could encounter is "make-ready" cost. These costs are associated with a need to upgrade a pole to accommodate third party utilities. This amount can vary based on the materials but can also vary based on the other attachers such as AT&T, Optimum, and Ozark Fiber wanting to share the space.

Finally, the agreement includes procedures for violation notices and maximum times for the company to respond to concerns or system issues needing repair and allowing for the City to force correction or at least the financial responsibility to correct them. This has historically, and still is a problem with some existing attachers where we have trouble getting them to move or repair issues on our poles.

### **Recommendation:**

Total Highspeed , LLC has reviewed and approved the agreement and staff recommends passage of this Council Bill authorizing the City Administrator to execute the agreement.

### **MEMO SUBMITTED BY:**

**Travis Cossey** | Assistant Director Nixa Utilities and Public Works

tcossey@nixa.com | 417-725-2353

**AN ORDINANCE OF THE COUNCIL OF THE CITY OF NIXA AUTHORIZING THE CITY ADMINISTRATOR TO EXECUTE A WIRELINE POLE ATTACHMENT AGREEMENT WITH TOTAL HIGHSPEED, LLC.**

**WHEREAS** Total Highspeed, LLC, has approached the City about installing and maintaining certain attachments to City electric and utility poles; and

**WHEREAS** City staff and staff with Total High Speed, LLC, have negotiated a proposed Wireline Pole Attachment Agreement, which is attached hereto as "Council Bill Exhibit A"; and

**WHEREAS** the City Council desires to authorize the City Administrator to execute the Agreement attached hereto as "Council Bill Exhibit A."

**NOW, THEREFORE, BE IT ORDAINED BY THE COUNCIL OF THE CITY OF NIXA, AS FOLLOWS, THAT:**

**SECTION 1:** The City Council hereby authorizes the City Administrator, or designee, to enter into a Wireline Pole Attachment Agreement with Total Highspeed, LLC. Said Agreement shall be in substantially similar form as the document attached hereto, and incorporated herein by this reference, as "Council Bill Exhibit A." The City Administrator and the officers of the City are hereby authorized to do all things necessary or convenient to carry out the terms and intent of this Ordinance.

**SECTION 2:** This Ordinance shall be in full force and effect from and after its final passage by the City Council and after its approval by the Mayor, subject to the provisions of section 3.11(g) of the City Charter.

**ADOPTED BY THE COUNCIL THIS 14th DAY OF January 2025.**

ATTEST:

\_\_\_\_\_  
PRESIDING OFFICER

\_\_\_\_\_  
CITY CLERK

**APPROVED BY THE MAYOR THIS \_\_\_\_\_ DAY OF January 2025.**

ATTEST:

\_\_\_\_\_  
MAYOR

\_\_\_\_\_  
CITY CLERK

APPROVED AS TO FORM:

\_\_\_\_\_  
CITY ATTORNEY

## WIRELINE POLE ATTACHMENT AGREEMENT

This Wireline Pole Attachment Agreement (the "Agreement") effective on the date of full execution by both Parties ("Effective Date") is made by and between the City of Nixa, Missouri, a Constitutional Charter City organized and existing under the laws of the State of Missouri ("City"), and Total Highspeed, LLC, a Missouri Limited Liability Company ("Licensee").

### RECITALS

**WHEREAS** City operates a municipal utility which performs the essential public service of distributing electric power; and

**WHEREAS** City is responsible for safeguarding the integrity of the City's electric system, obtaining fair compensation for the use of its infrastructure through collection of fees and other charges, ensuring compliance with all applicable federal, state and local laws, rules and regulations, ordinances, and standards and policies, and permitting fair and reasonable access to the City's Poles; and

**WHEREAS** Licensee proposes to install and maintain Attachments and Facilities ("Licensee's Attachments"), on City Poles; and

**WHEREAS** the City is willing, when it may lawfully do so, to issue one or more Permits authorizing the placement or installation of Licensee's Attachments on City Poles, upon Licensee's compliance with the terms of this Agreement; and

**WHEREAS** the Parties intend that this Agreement shall replace and supersede all previous pole attachment and or infrastructure use agreements between the Parties upon the Effective Date of this Agreement.

**NOW, THEREFORE**, in consideration of the mutual covenants, terms and conditions set out herein the Parties agree as follows:

### ARTICLE 1. DEFINITIONS.

For the purposes of this Agreement, the following terms, phrases, words, and their derivations, shall have the meaning given below, unless more specifically defined within a specific Article or Paragraph of this Agreement. When not inconsistent with the context, words used in the present tense include the future and past tense, and words in the singular number include the plural number. The words "shall" and "will" are mandatory and "may" is permissive. Words not defined shall be given their common and ordinary meaning.

- 1.1. **Affiliate**: when used in relation to Licensee, means another entity that owns or controls, is owned or controlled by, or is under common ownership or control with Licensee.
- 1.2. **Applicable Standards**: means all engineering and safety standards governing the installation, maintenance, and operation of City Facilities, City Poles, and Cable Facilities and the performance of all work in or around electric utility facilities. Such term ("Applicable Standards") includes, without limitation, the most current versions of the National Electric Safety Code ("NESC"), the National Electrical Code ("NEC"), the regulations of the Occupational Safety and Health Administration ("OSHA"), and any adopted codes or ordinances of the City, each of which is incorporated by reference in this Agreement, and/or other reasonable safety and engineering

requirements of the City as set forth in Appendix C or other federal, state, or local authority with jurisdiction over utility facilities (collectively "Applicable Standards"), provided such requirements are applied on a non-discriminatory basis to City attachments and all other Attachments and provided further that the City may waive or modify any such Applicable Standards upon request by Licensee in a Permit (e.g., may permit Licensee's Attachments within the space traditionally reserved for electric power). All future updates or revisions of said Applicable Standards are hereby incorporated herein, and the Parties agree that during regular maintenance repair and new construction, that an Attachment installed in compliance with the Applicable Standards in effect at the time of the installation shall be deemed in compliance notwithstanding subsequent changes to Applicable Standards, unless those changes are required by law to be made to existing Attachments or are required to insure safety or reliability ("Nonconforming Attachment").

- 1.3. **Attaching Entity:** means any public or private entity, including Licensee, which pursuant to an attachment agreement with the City, places an Attachment on a City Pole.
- 1.4. **Attachment(s):** means Cable Facilities that are placed directly on City Poles in the designated Communication Space but does not include a Riser. New Attachments permitted after the Effective Date of this Agreement shall only occupy twelve (12) inches of vertical space on a Pole, as measured either above or below (but not both) the point of attachment, and any Attachment outside of the twelve inches shall be deemed to constitute a separate Attachment for Pole Attachment Fee calculation purposes.
- 1.5. **Cable Facilities:** means wireline infrastructure used to deliver voice, data, broadband, internet, communication services, or other forms of digital or analog signals, including but not limited to, fiber optic, copper, and/or coaxial cables, and Strand Mounted Micro Wireless Facilities.
- 1.6. **Capacity:** means the ability of a Pole to accommodate an additional attachment based on Applicable Standards that include space and loading considerations.
- 1.7. **City Facilities:** means all personal property and real property owned or controlled by the City, including Poles, Conduit System, and related facilities.
- 1.8. **Climbing Space:** means that portion of a Pole's surface and surrounding space that is free from encumbrances to enable City employees and contractors to safely climb, access, and work on City Poles, Facilities, and equipment.
- 1.9. **Correct:** means to perform work to bring an Attachment into compliance with Applicable Standards.
- 1.10. **Emergency:** means a situation exists which, in the reasonable discretion of Licensee or City, if not remedied immediately, poses an imminent threat to public health, life, or safety, damage to property or a service outage.
- 1.11. **Equipment Attachment:** means each power supply, amplifier, pedestal, appliance or other single device or piece of equipment affixed to any City Pole or City Utility Facilities.
- 1.12. **Licensee:** means Total Highspeed, LLC, and its authorized successors and assignees.
- 1.13. **Make-Ready or Make-Ready Work:** means all work that the City reasonably determines to be required to accommodate Licensee's Cable Facilities to comply with all Applicable Standards.

Such work includes, but is not limited to, rearrangement and/or transfer of City Facilities, existing Attachments, or attachments of other Attaching Entities, inspections, engineering work, permitting work, tree trimming (other than tree trimming performed for normal maintenance purposes), pole replacement and construction, but does not include Licensee's routine maintenance.

- 1.14. **Notification:** means written or electronic notice of Licensee's plans for installation of Overlash or a Strand Mounted Micro Wireless Facility.
- 1.15. **Occupancy:** means the use or reservation of space for Attachments on a City Pole.
- 1.16. **Overlash:** means to place an additional wire or Cable Facility onto an existing Attachment.
- 1.17. **Pedestals/Vaults/Enclosures:** means above- or below-ground housings that are not attached to Poles but are used to enclose a cable/wire splice, power supplies, amplifiers, passive devices, and/or to provide a service connection point.
- 1.18. **Permit:** means written or electronic authorization by the City for Licensee to make or maintain Attachments to specific City Poles pursuant to the requirements of this Agreement and any Applicable Standards. Licensee's Attachments made prior to the Effective Date and authorized by City ("Existing Attachments") shall be deemed Permitted Attachments hereunder.
- 1.19. **Pole:** means a pole owned or controlled by the City that is used for the distribution of electricity and is capable of supporting Attachments for Licensee's Cable Facilities.
- 1.20. **Pole Loading Study/Analysis:** means the engineering analysis of the existing and proposed loads on a Pole. The study, where not previously performed by the City or where not otherwise required by the City, shall be done using the following pole loading programs, O-Calc or PLS Pole using liner analysis Grade C Construction and City Pole Attachment Standards in Appendix C.
- 1.21. **Post-Installation Inspection:** means the inspection by the City or Licensee or some combination of both to verify that the Attachments have been made in accordance with Applicable Standards and the Permit or Notification.
- 1.22. **Pre-Construction Survey:** means all work or operations required by Applicable Standards to determine the Make-Ready Work necessary to accommodate Licensee's Cable Facilities on a Pole. Such work includes, but is not limited to, a Pole Loading Study, where not previously performed by the City or where otherwise required by the City, field inspection and administrative processing.
- 1.23. **Reserved Capacity:** means capacity or space on a Pole that the City has identified and reserved for its own future requirements at the time of the Permit grant.
- 1.24. **Riser:** means metallic or plastic encasement materials placed vertically on the Pole to guide and protect wires and cables.
- 1.25. **Service Drop:** means cables, wires, and strands that serve to connect a customer to the service provider's distribution network in order to provide service to said customer.



- 1.26. **Strand Mounted Micro Wireless Facility:** means any device or Facility that is no larger in dimension than twenty-four inches in length, fifteen inches in width, and twelve inches in height, with an exterior antenna no longer than eleven inches and which is self-contained and mounted on the strand to provide wireless communications, but specifically does not include a pole mounted Micro Wireless or Small Cell Wireless facility.
- 1.27. **Tag:** means to place distinct markers on wires and cables, coded by color or other means specified by the City and/or applicable federal, state or local regulations that will readily identify the type of Attachment (e.g., cable TV, telephone, high-speed broadband data, public safety) and its owner.
- 1.28. **Unauthorized Attachment:** means any Attachment or Overlash placed on City Pole(s) without such Authorization or Notification as is required by this Agreement, provided the Licensee's Permitted Attachments as of the Effective Date of this Agreement shall not be considered Unauthorized Attachments.

## **ARTICLE 2. SCOPE OF AGREEMENT.**

- 2.1 **Grant of License.** Subject to the provisions of this Agreement, the City grants Licensee a revocable, nonexclusive, license authorizing Licensee to install and maintain Attachments to the City's Poles.
- 2.2 **No Small Cell Wireless Attachments.** With the exception of Strand Mounted Micro Wireless Facilities, this Agreement does not contemplate or authorize the attachment of small cell wireless attachments to City Poles, and such use will only be allowed pursuant to the City's Small Cell Wireless regulations, as may be amended, including without limitation Chapter 25 of the Nixa City Code. See Appendix E regarding Strand Mounted Micro Wireless Facilities.
- 2.3 **Parties Bound by Agreement.** Licensee and the City agree to be bound by all provisions of this Agreement.
- 2.4 **Permit Issuance Conditions.** The City will issue one or more Permit(s) to Licensee only when City determines, in its sole judgment, exercised reasonably, that (i) it has sufficient Capacity to accommodate the requested Attachment(s) taking into account the Licensee's willingness to resolve any sufficiency issue through Make-Ready, (ii) Licensee meets all requirements set forth in this Agreement, and (iii) such Permit(s) comply with all Applicable Standards.
- 2.5 **Reserved Capacity.** Access to space on City Poles will be made available to Licensee subject to Reserve Capacity for future City use. At the time of Permit issuance, the City shall notify Licensee if capacity on particular Poles is being reserved for future use. For Attachments made with notice of such a Reservation of Capacity, upon giving Licensee at least sixty (60) days prior notice, the City may reclaim such Reserved Capacity at any time following the installation of Licensee's Attachment if required for the City's future use. The City shall reclaim Reserved Capacity from the Attaching Entity(s) in order of the most recent Attaching Entity to have attached its Cable Facilities or Equipment Attachments to the Pole upon which the City is reclaiming the Reserved Capacity. If reclaimed for City use, the City may at such time also install associated facilities, including the attachment of cable lines for internal City operational or governmental cable requirements. The City shall give Licensee the option to remove its Attachment(s) from the affected Pole(s) or to pay for the cost of any Make-Ready Work needed

to expand Capacity for core utility service requirements, so that Licensee can maintain its Attachment on the affected Pole(s). The allocation of the cost of any such Make-Ready Work (including the transfer, rearrangement, or relocation of third-party Attachments) shall be determined in accordance with Article 11. Licensee shall not be required to bear any of the costs of rearranging or replacing its Attachment(s), if such rearrangement or replacement is required as a result of an additional attachment or the modification of an existing attachment sought by any other entity or if the City installs cable lines that will be used for commercial communications purposes.

- 2.6 No Interest in Property.** No use, however lengthy, of any City Facilities, and no payment of any fees or charges required under this Agreement, shall create or vest in Licensee any easement or other ownership or property right of any nature in any portion of such Facilities. Neither this Agreement, nor any Permit granted under this Agreement, shall constitute an assignment of any of the City's rights to City Facilities. Notwithstanding anything in this Agreement to the contrary, Licensee shall, at all times, be and remain a Licensee only.
- 2.7 Licensee's Right to Attach.** Nothing in this Agreement, other than a Permit issued pursuant to Article 6, shall be construed as granting Licensee any right to attach Licensee's Cable Facilities to any specific Pole.
- 2.8 City's Rights over Poles.** The Parties agree that this Agreement does not in any way limit the City's right to locate, operate, maintain, or remove its Poles in the manner that will best enable it to fulfill its service requirements or to comply with any federal, state, or local legal requirement.
- 2.9 Expansion of Capacity.** The City will take reasonable steps to expand Pole Capacity when necessary to accommodate Licensee's request for Attachment. It shall not be considered reasonable for the City to refuse to expand Pole Capacity, including pole replacement, if the Licensee agrees to bear the cost for resolving the Capacity issue, unless other safety concerns are implicated. Notwithstanding the foregoing sentence, nothing in this Agreement shall be construed to require the City to install, retain, extend, or maintain any Pole for use when such Pole is not needed for the City's own service requirements.
- 2.10 Other Agreements.** Except as expressly provided in this Agreement, nothing in this Agreement shall limit, restrict, or prohibit the City from fulfilling any agreement or arrangement regarding its Poles into which the City has previously entered with others not party to this Agreement.
- 2.11 Permitted Uses.** Nothing in this Agreement shall be construed to require the City to allow Licensee to use City Poles after the termination of this Agreement.
- 2.12 Overlapping.** The following provisions apply to Overlapping:
- 2.12.1** Licensee shall Overlap, in accordance with the requirements of Article 6. Overlapping will be limited to fiber, coaxial cables, and Strand Mounted Micro Wireless Facilities, and only on a permanent basis. Absent such authorization, Overlapping constitutes an Unauthorized Attachment under Article 21.
- 2.12.2** Overlapping by Licensee will be allowed by the City if such Overlapping can be accomplished consistent with the Applicable Standards, subject to any notice regarding Reserve Capacity pursuant to Paragraph 2.5. Authorized Overlapping shall not increase the Annual Attachment Fee paid pursuant to Appendix A. Licensee shall, however, be



responsible for all Make-Ready Work and other charges associated with the Overlashing. Licensee shall not have to pay a separate Annual Attachment Fee for such Overlashing.

**2.12.3** Make-Ready Work procedures set forth in Article 7 shall apply, as necessary, to all Overlashing.

**2.12.4** Licensee shall provide notice to City prior to installation and again within thirty (30) days following the installation of Overlashing.

**2.13** **Enclosures.** Licensee shall not place Pedestals, Vaults, and/or other Enclosures within four (4) feet of any Pole or other City Facilities without City's prior written permission. If permission is granted, all such installations shall be per the Applicable Standards. Such permission shall not be unreasonably withheld. If the proposed Pedestal, Vault, and/or other Enclosures are to be placed within the City's right-of-way then Licensee shall obtain an encroachment permit pursuant to Chapter 24 of the Nixa City Code, as may be amended.

### **ARTICLE 3. FEES AND CHARGES.**

**3.1** **Payment of Fees and Charges.** Licensee shall pay to the City the fees and charges specified in this Agreement, including those charges referenced in Appendix A, and shall comply with the terms and conditions specified in this Agreement.

**3.2** **Payment Period.** Unless otherwise expressly provided, Licensee shall pay any invoice it receives from the City pursuant to this Agreement within thirty (30) days of receipt of invoice.

**3.3** **Application Fee.** Licensee shall be charged a non-refundable Application Fee for each Pole for which it seeks to make an Attachment. City reserves the right to adjust the Application Fee from time to time to cover actual and documented costs incurred in processing Applications. Failure to include Application Fees will cause the Application(s) to be deemed incomplete, and City will not process such Application(s) until the Application Fees are paid. City will make reasonable efforts to contact Licensee should its Application Fee not be received.

**3.4** **Attachment Fee.** Licensee shall be charged an Annual Attachment fee ("Attachment Fee") per year, as set out in Appendix A. The Annual Attachment Fee shall be adjusted annually, as set out in Appendix A.

**3.5** **Billing of Attachment Fee.** The City shall invoice Licensee for the per-Pole Attachment Fee annually. The City will submit to Licensee an invoice for the annual rental period not later than January 31<sup>st</sup> of each year. The initial annual rental period shall commence upon the Effective Date of this Agreement and conclude on December 31 of that year. Each subsequent annual rental period shall commence on the following January 1<sup>st</sup> and conclude on December 31<sup>st</sup> of that year. The invoice shall set forth the total number of City Poles on which Licensee was issued Permit(s) for Attachments during such annual rental period, including any previously authorized and valid Permits.

**3.5.1** **Contesting Fee.** Licensee shall have forty-five (45) days from receipt of invoice to contest the number of Attachments. Failure to contest or otherwise dispute the invoice within forty-five (45) days of receipt shall be deemed to be acceptance by the Licensee. In the event that Licensee does contest within forty-five (45) days either the number of Attachments or the Attachment Fee, Licensee shall pay an amount equivalent to the

previous year's billing within the initial forty-five (45) days. Upon resolution of the disagreement regarding the then-current year's bill, either Licensee shall pay the difference, if the agreed amount is greater than Licensee's initial payment, or the City shall refund the difference to Licensee, if the agreed amount is less than Licensee's initial payment.

- 3.6 Refunds.** No fees and charges specified in this Agreement or Appendix A shall be refunded on account of any surrender of a Permit granted under this Agreement.
- 3.7 Late Charge(s).** If the City does not receive payment for any undisputed fee or other amount owed within forty-five (45) days after it becomes due, Licensee shall pay interest to the City at the rate of one- and one-half percent (1.5%) per month, or the maximum interest allowed by law, whichever is greater, on the amount due from the date payment was due. In addition to assessing interest on any unpaid fees or charges, if any fees or charges remain unpaid for a period exceeding ninety (90) days the City may discontinue the processing of applications for new Attachments until such fees or charges are paid.
- 3.8 Charges and Expenses.** Licensee shall reimburse the City and any other Attaching Entity for those actual and documented costs incurred for facilitating Licensee's Attachments or for which Licensee is otherwise responsible under this Agreement.
- 3.8.1** Such costs and reimbursements shall include, but not be limited to, all costs associated with de-energizing City's Facilities, all design, engineering, administration, supervision, payments, labor, overhead, materials, equipment and applicable transportation used for work on, or in relation to Licensee's Attachments as set out in this Agreement or as requested by Licensee in writing.
- 3.9 Advance Payment.** The City in its sole discretion will determine the extent to which Licensee will be required to pay in advance estimated costs of the City, including, but not limited to, administrative, construction, inspections, and Make-Ready Work costs, in connection with the initial installation or rearrangement of Licensee's Attachments pursuant to the procedures set forth in Articles 6 and 7 below.
- 3.10 True-Up/True-Down.** Whenever the City, in its discretion, requires advance payment of its estimated expenses prior to undertaking an activity on behalf of Licensee and the actual cost of the activity exceeds the advance payment of estimated expenses, Licensee agrees to pay City for the difference in cost, provided that the City documents such costs with sufficient detail to enable Licensee to verify the charges. To the extent that the City's actual cost of the activity is less than the estimated cost, the City shall refund to Licensee the difference in cost.
- 3.11 Determination of Charges.** Wherever this Agreement requires Licensee to pay for work done or contracted by the City, the charge for such work shall include all reasonable material, labor, engineering, administrative, and applicable overhead costs. The City shall bill its services based upon actual costs, and such costs will be determined in accordance with the City's cost accounting systems used for recording capital and expense activities. All such invoices shall include an itemization of dates of work, location of work, labor costs per hour, persons employed, and costs of materials used. Labor costs shall be the fully loaded costs of the labor title performing the work. Consistent with Article 19, if Licensee was required to perform work and fails to perform such work within the specified time, and City performs such work, the City may

charge Licensee an additional ten (10%) of its actual and documented costs for completing such work.

- 3.12 Work Performed by City.** Wherever this Agreement requires the City to perform any work, the City, at its sole discretion, may utilize its employees or contractors, or any combination of the two, to perform such work.
- 3.13 Charges for Incomplete Work.** In the event that an Application is submitted by Licensee and then steps are taken by the City to carry out the review of the Application by performing necessary engineering and administrative work and the Application is subsequently cancelled, Licensee shall reimburse the City for all of the actual and documented costs incurred by the City through the date of cancellation, including engineering, clerical, administrative and Make-Ready construction costs.

#### **ARTICLE 4. SPECIFICATIONS.**

- 4.1. Installation.** When a Permit is issued pursuant to this Agreement, Licensee's Cable Facilities and Attachments shall be installed and maintained in accordance with all Applicable Standards. Licensee shall be responsible for the installation and maintenance of its Cable Facilities and Attachments.
- 4.2. Maintenance of Facilities.** Licensee shall, at its own expense, make and maintain its Attachment(s) in safe condition and good repair, in accordance with all Applicable Standards. Licensee shall not be required to update or upgrade its Attachments if they met Applicable Standards at the time they were installed unless such updates or upgrades are needed because there is an imminent danger. When the City believes that an Attachment poses an imminent danger to the physical integrity of City Poles, City Facilities, the public, or City workers, then the City may perform such work and/or take action as it deems necessary without first giving notice to Licensee and Licensee shall indemnify the City for any such work. Licensee will bring into conformity with the new Applicable Standards any such Attachments that complied when made, at the time of their normal replacement, rebuilding, or reconstruction; unless applicable law requires that the changes must be implemented sooner.
- 4.3. NJUNS.** Licensee shall become a participating member of the National Joint Utility Notification System ("NJUNS"), to facilitate required notices, including, but not limited to, any need to rearrange or transfer Licensee's Attachments. City will determine the extent to which notifications via NJUNS will be utilized for Pole Attachments, transfers, rearrangements, Pole Attachment abandonment and removal, as well as the extent to which such use will satisfy the notification requirements of this Agreement and provide notice thereof to Licensee. To the extent that City determines to use NJUNS, Licensee and the City agree to perform their respective tasks set forth in NJUNS tickets in a commercially reasonable and timely manner and in accordance with the timeframes specified in this Agreement.
- 4.4. Tagging.** Licensee shall Tag all its Cable Facilities every 3<sup>rd</sup> pole as specified in Appendix C and/or applicable federal, state, and local regulations upon installation of such Facilities. Within one year of the execution of this Agreement, Licensee shall also tag any untagged Cable Facilities as specified in Appendix C, which were on City Poles on the Effective Date of this Agreement. Failure to provide proper tagging will be considered a violation of the Applicable Standards.

- 4.5. Interference.** Licensee shall not allow its Cable Facilities to impair the ability of the City or any third party with superior rights to use City Poles, nor shall Licensee allow its Cable Facilities to interfere with the lawful operation of any City Facilities or third-party facilities.
- 4.6. Protective Equipment.** Licensee and its employees and contractors shall utilize and install adequate protective equipment to ensure the safety of people, City Facilities, and the Attachments and Cable Facilities of other Attaching Entities, including the City. Licensee shall, at its own expense, install protective devices designed to handle the electric voltage and current carried by the City's Facilities in the event of a contact with such City Facilities. City shall not be liable for any actual or consequential damages to Licensee's Facilities, Licensee's customers' Facilities, or to any of Licensee's employees, contractors, customers, or other persons resulting from the lack of protective equipment.
- 4.7. Violation of Specifications.** If Licensee's Attachments or any part of them, are installed, used, or maintained in violation of this Agreement, and Licensee has not corrected the violation(s) within thirty (30) days from receipt of written notice of the violation(s) from the City, the provisions of Article 19 shall apply. When the City believes, however, that such violation(s) pose an imminent threat to the safety of any person, interfere with the performance of the City's service obligations, or present an imminent threat to the physical integrity of City Poles or City Facilities, the City may perform such work and/or take such action as it deems necessary without first giving written notice to Licensee. As soon as practicable afterward, the City will advise Licensee of the work performed or the action taken. Licensee shall be responsible for all actual and documented costs incurred by the City in acting pursuant to this Paragraph 4.7. Licensee shall indemnify the City for any such work.
- 4.8. Emergency Restoration of City Service.** The City's emergency service restoration requirements shall take precedence over any and all work operations of Licensee on City Poles.
- 4.9. Effect of Failure to Exercise Access Rights.** If Licensee does not exercise any access right granted pursuant to this Agreement and/or applicable Permit(s) within one hundred twenty (120) days of the effective date of such right and any extension to such Permit(s), the City may, but shall have no obligation to, use the space scheduled for Licensee's Attachment(s) for its own needs or make the space available to other Attaching Entities. In such instances, the City shall endeavor to make other space available to Licensee, upon written application under Article 6, as soon as reasonably possible and subject to all requirements of this Agreement, including the Make-Ready Work provisions. If the City uses the space for its own needs or makes it available to other parties, then from the date that the City or a third party begins to use such space, for purposes of this paragraph, Licensee's access rights shall not be deemed effective until any necessary Make-Ready Work has been performed.
- 4.10. Removal of Nonfunctional Attachments.** At its sole expense, Licensee shall remove any of its Attachments or Service Drops or any part thereof that becomes nonfunctional and no longer fit for service, or any Attachments or Service Drops which are abandoned or not in use by Licensees, ("Nonfunctional Attachment") as provided in this Paragraph 4.10. A Nonfunctional Attachment that Licensee has failed to remove as required in this paragraph shall constitute an Unauthorized Attachment and is subject to the Unauthorized Attachment fee specified in Appendix A. Except as otherwise provided in this Agreement, Licensee shall remove Nonfunctional Attachments within one (1) year of the Nonfunctional Attachment becoming nonfunctional, unless Licensee receives written notice from the City that removal is necessary to accommodate the City's or another Attaching Entity's use of the affected Pole(s), in which



case Licensee shall remove the Nonfunctional Attachment within sixty (60) days of receiving the notice. If Licensee contests whether the Attachment is nonfunctional, provisions of Article 28 shall apply. Where Licensee has received a Permit to Overlash a Nonfunctional Attachment, such Nonfunctional Attachment must first be removed after which the Licensee will apply for an Attachment. In such case, no additional Attachment Fee will be charged assuming the Licensee was already paying for the Nonfunctional Attachment. Licenses shall give the City notice as soon as practicable of any Nonfunctional Attachment along with the date the Nonfunctional Attachment was removed.

## **ARTICLE 5. PRIVATE AND REGULATORY COMPLIANCE.**

- 5.1. Necessary Authorizations.** Before Licensee occupies any of the City's Poles, Licensee shall obtain from the appropriate public or private authority, or from any property owner or other appropriate person, any required authorization to construct, operate, or maintain its Cable Facilities on public or private property. City retains the right to require evidence that appropriate authorization has been obtained before any Permit is issued to Licensee. Licensee's obligations under this Article 5 include, but are not limited to, its obligation to obtain all necessary approvals to occupy public/private rights-of-way and easements and all necessary licenses and authorizations to provide the services that it provides over its Cable Facilities. Licensee shall defend, indemnify, and reimburse the City for all losses, costs, and expenses, including reasonable attorney's fees that the City may incur as a result of claims by governmental bodies, owners of private property, or other persons, that Licensee does not have sufficient rights or authority to attach Licensee's Cable Facilities on City Poles to provide particular services.
- 5.2. Lawful Purpose and Use.** Licensee's Cable Facilities must at all times serve a lawful purpose, and the Licensee's use of such Facilities must comply with all applicable federal, state, and local laws.
- 5.3. Forfeiture of City Rights.** No Permit granted under this Agreement shall extend, or be deemed to extend, to any of City Poles, to the extent that Licensee's Attachment would result in a forfeiture of the City's rights. Any Permit that would result in forfeiture of City rights shall be deemed invalid as of the date that the City granted it. Further, if any of Licensee's existing Cable Facilities, whether installed pursuant to a valid Permit or not, would cause such forfeiture, Licensee shall promptly remove its Facilities upon receipt of written notice from the City. If Licensee does not remove its Cable Facilities in question within sixty (60) days of receiving written notice from the City, the City may, at its option, perform such removal at Licensee's expense. Notwithstanding the forgoing, Licensee shall have the right to contest any such forfeiture before any of its rights are terminated, provided that Licensee shall indemnify the City for liability, costs, and expenses, including reasonable attorney's fees, which may accrue during Licensee's challenge.
- 5.4. Effect of Consent to Construction/Maintenance.** Consent by the City to the construction or maintenance of any Attachments by Licensee shall not be deemed consent, authorization, or acknowledgment that Licensee has obtained all required Authorizations with respect to such Attachment.

## **ARTICLE 6. PERMIT APPLICATION AND NOTIFICATION PROCEDURES.**

- 6.1. Permit or Notification Required.** Before making any Attachments, (excluding Anchors and Riser Attachments where there is an existing licensed Pole Attachment) to any City Poles,



Licensee shall submit an Application and receive a Permit therefor, with respect to each Pole. Overlashing and Strand Mounted Micro Wireless Facility installations require Notification in advance of installation. See Appendix B Pole Attachment Application and Overlash/Strand Mounted Micro Wireless Facility Notification Form.

**6.2. Overlashing Notification Process.** Overlashing and Strand Mounted Micro Wireless Facilities are subject to the following notification process.

- 6.2.1.** Licensee shall provide Notification of Overlashing and Strand Mounted Micro Wireless Facility installations to the City at least 10 working days prior to installation. The required notification shall be made using the Attachment Permit and Overlash/Strand Mounted Micro Wireless Notification Form included in Appendix B as attached hereto, and shall include: (1) a description of the area where the installation will be done including route maps and pole locations; (2) a description of the installation; (3) a representation that the installation will not require any space other than the space previously designated for Licensee's Facilities; (4) an authorized representative of Licensee's certification that the installation will not impair the structural integrity of the Poles involved or violate Applicable Standards; and (5) not cause any other Attachments to the Poles to be adversely affected by such installation or fall out of compliance with the above-referenced requirements. The authorized representative of Licensee shall be a qualified and experienced professional engineer, employee, or contractor of Licensee who has been approved by the City.
- 6.2.2.** It is Licensee's responsibility to verify in advance that the Pole and strand to which it proposes to install will meet all Applicable Standards including NESC Pole Loading and Clearance. Licensee shall be responsible for the costs of all Make-Ready Work necessary to accommodate the Overlash and/or Strand Mounted Micro Wireless Facility installation.
- 6.2.3.** Licensee shall be deemed authorized to proceed with the proposed Overlash and/or Strand Mounted Micro Wireless Facility installation ten (10) working days after it has submitted its complete Notification.
- 6.2.4.** Overlashing and Strand Mounted Micro Wireless Facilities are subject to Notification only. In addition to notification prior to installation, Licensee shall notify the City within thirty (30) days of the completed installation and provide verification that it meets all Applicable Standards.
- 6.2.5.** Any Overlash Attachment and/or Strand Mounted Micro Wireless Facility Attachment which may be installed and in which the City was not provided prior written Notification thereof shall be considered an Unauthorized Attachment subject to the provisions of Article 21.

**6.3. Service Drops.**

- 6.3.1.** Licensee may attach a Service Drop, with Application, from one Pole with an existing Authorized Attachment to connect directly to Licensee's customer's building, premise, or location, and attached to no more than one additional Pole where the additional Pole does not support voltage greater than 600V.
- 6.3.2.** It is Licensee's responsibility to verify that the Pole on which it proposes to make a Service Drop meets all Applicable Standards before attaching the Service Drop. If existing

standards issues are identified it is the responsibility of the Licensee to notify City of the issue(s). Licensee shall not be allowed to attach the Service Drop until the Applicable Standards issue is resolved.

**6.3.3.** If it is determined, by the City, that Licensee has attached a Service Drop on a Pole with a pre-existing violation of Applicable Standards, Licensee shall be required to bring the Service Drop into compliance with Applicable Standards to the extent that it is Licensee's existing Attachment that is non-compliant. Subject to the provisions of Article 18, the City will provide written notice to Licensee and Licensee will have thirty (30) days from receipt of such notice to correct the existing standards issue, otherwise the provisions of Article 19 shall apply. If the Attachment that is non-compliant belongs to another Attaching Entity, then Licensee shall coordinate with City and the other Attaching Entity concerning any necessary rearrangement of Licensee's Service Drop in conjunction with the Correction of the non-compliant Attachment.

**6.3.4.** For Service Drops Licensee shall submit an Attachment Permit request within thirty (30) days of installation. Any such service drop attachment without a permit will be considered an Unauthorized Attachment subject to the provisions of Article 21. If an Attachment Permit Application for a Service Drop is denied but the Service Drop has already been installed on a Pole, then Licensee shall have 30 days to bring the Service Drop into compliance. Any Service Drop not brought into compliance shall be deemed a Nonfunctional Attachment and shall be subject to the provisions of Paragraph 4.10.

**6.4. Pre-Existing Attachments.** Licensee shall not be required to obtain Permits for authorized Attachment(s) existing as of the Effective Date of this Agreement as specified in the inventory referenced in subsection 6.4.1 (the "Attachment Inventory"). Such Nonconforming Attachments shall, however, be subject to the Annual Attachment Fees specified in Appendix A, and such Attachments shall be subject to the Applicable Standards in accordance with Paragraph 1.2. Following the Effective Date of this Agreement, Unauthorized Attachments not accounted for in the Attachment Inventory will have the same requirements as a new Attachment. Licensee shall pay the Pole Attachment Fees back to the date of the last inventory, in addition to the penalty for the Unauthorized Attachments. See Appendix A.

**6.4.1.** [This paragraph is intentionally left blank.]

**6.4.2.** Any existing Pole Attachments found that need Correcting to be in compliance with the Applicable Standards shall be addressed pursuant to Article 18 and Article 19.

**6.4.3.** Licensee will participate in all scheduled Pole Attachment surveys conducted after the Effective Date of this Agreement by the City and will split the cost of such audit proportionately by number of Attachments with all other parties with Attachments on the Poles. See Article 20.

**6.5. Permit Certification.** Unless otherwise waived in writing by the City, as part of the Permit Application process, and at Licensee's sole expense, a qualified and experienced professional engineer, or employee or contractor of Licensee, who has been approved by the City, must participate in the Pre-Construction Survey, conduct the Post-Installation Inspection, and certify that Licensee's Cable Facilities can be and were installed on the identified Poles in compliance with the Applicable Standards and in accordance with the Permit. The employee's or Other Approved Party's qualifications must include experience performing such work, or substantially

similar work, on electric transmission or distribution systems but does not require the employee to possess a particular license or certification. The City may require the Licensee's employee or Other Approved Party to conduct a post-installation inspection that City Utilities will verify by means that it deems to be reasonable.

- 6.6. Submission and Review of Permit Application.** Licensee will submit a properly executed Pole Attachment Permit Application, which shall include a Pre-Construction Survey and detailed plans for the proposed Attachments, including a description of any necessary Make-Ready Work to accommodate the Attachments by an experienced employee as described in Paragraph 6.5 and a pole loading study unless waived by the City in writing. Such Permit Application shall identify any modifications or deviations from any Applicable Standards requested by Licensee. Licensee will use the City's Pole Attachment Permit Application form, see Appendix B. The City may amend the Pole Attachment Permit Application form from time to time, provided that any such changes are not inconsistent with the terms of this Agreement and are applied to all Attaching Entities on a non-discriminatory basis. The City's acceptance of the submitted design documents does not relieve Licensee of full responsibility for any errors and/or omissions in the engineering analysis. Unless otherwise agreed, under normal circumstances, the Permit Application process shall be as follows:
- 6.7. Application Process.** Upon Licensee's submission of a properly executed and complete Permit Application for routine installations, The City will review and respond to said application as promptly as is reasonable and make best efforts to comply with the following timeframes:
- 6.7.1.** For Permit Applications seeking Attachments to fifty (50) or more Poles, the City will make every effort to review with a goal of providing a response within a thirty (30) to forty-five (45) day timeline but may require additional time. The City and Licensee may mutually agree on a timeline that exceeds 45 days on projects as needed. On these types of Permit Applications, the City may utilize qualified contractors to facilitate the application process at the Applicant's cost.
- 6.7.2.** The City's response will either: (i) grant permission to undertake such Make-Ready as described in Licensee's Application and engineering survey; (ii) grant permission to undertake such Make-Ready as the City reasonably determines is required; (iii) provide a cost estimate for the City's portion of any required Make-Ready in the case of (i) or (ii); or (iv) provide a written explanation as to why the Application is being denied, in whole or in part, for reasons of safety, reliability or insufficient Capacity that cannot be resolved consistent with Applicable Standards, including the City and county zoning and construction ordinances, as applicable.
- 6.8. Response to Estimate.** Upon receipt of the City's response, Licensee shall have fourteen (14) days to approve the estimate of any proposed Make-Ready Work and provide payment in accordance with this Agreement and the specifications of the estimate.
- 6.9. Permit as Authorization to Attach.** Upon completion and inspection of any necessary Make-Ready Work and receipt of payment for such work, the City will sign and return the Permit Application, which shall serve as authorization for Licensee to make its Attachment(s).
- 6.10. Notification to City.** Within thirty (30) days of completing the installation of an Attachment (including Overlash, Strand Mounted Wireless Facility, Riser Attachments, and/or Service Drops) Licensee shall provide written notice to City.

## **ARTICLE 7. MAKE-READY WORK/INSTALLATION.**

- 7.1. Estimate for Make-Ready Work.** If the City determines that it can accommodate Licensee's request for Attachment(s), it will, upon request, advise Licensee of any estimated Make-Ready Work costs necessary to accommodate the Attachment. Determination consists of pole loading studies performed by the Licensee, and inspection by City.
- 7.2. Who May Perform Make-Ready.** Make-Ready Work in the electric supply space may be performed only by the City and/or a qualified contractor authorized by the City to perform such work. Under normal circumstances, the City will give Licensee the option of either having the City perform any necessary Make-Ready Work, at Licensee's cost, or allowing Licensee to complete Make-Ready Work through the use of qualified contractors authorized by the City, which authorization shall not be unreasonably withheld. Licensee shall be responsible for the costs associated with the Make Ready Work for its Attachments, regardless of who performed the Make Ready Work.
- 7.3. Time Frame for Completion of Make-Ready.** If the City is performing Make-Ready Work, it will make best efforts to complete routine Make-Ready Work within ninety (90) days of receipt of Licensee's approval of the Make-Ready estimate (and advance payment if required). If there are extenuating circumstances that make the necessary Make-Ready more complicated or time-consuming, including, but not limited to, the Application requesting Attachments to more than fifty (50) Poles, or seasonal weather conditions, the City shall identify those factors in the Make-Ready description and cost estimate and the Parties shall mutually agree upon a reasonable timeframe for completion. If the City does not complete agreed upon Make-Ready work within (90) days, or the agreed-upon timeframe, it will allow Licensee to use a City approved, qualified contractor to complete such Make-Ready Work and refund any amounts paid by Licensee to the City for performing such Make-Ready Work that is not completed. The City shall provide a list of such qualified contractors.
- 7.3.1.** The above notwithstanding, if the City has substantially completed the Make-Ready, the Parties will reasonably determine whether it makes more sense from an operational efficiency perspective to have the City complete the work rather than have Licensee's authorized, qualified contractors do the work.
- 7.4. Scheduling of Make-Ready Work.** In performing all Make-Ready Work to accommodate Licensee's Attachments, the City will endeavor to include such work in its normal work schedule. If Licensee requests, and the City agrees to perform Make-Ready Work on a priority basis or outside of the City's normal work hours, Licensee will pay any resulting increased actual and documented costs. Nothing in this Agreement shall be construed to require the City to perform Licensee's work outside normal work hours, before other scheduled work, or City service restoration.
- 7.5. Payment for Make-Ready Work.** Upon completion of the Make-Ready Work performed by the City, or at such time as Licensee notifies the City it is not proceeding with the project set out in the Application for which Make-Ready Work is being performed, the City shall invoice Licensee for the City's actual and documented cost of such Make-Ready Work. The costs of the Make-Ready Work shall be itemized, and if the City receives advance payment, the costs shall be trued up, in accordance with Article 3. Licensee shall be responsible for entering into an



agreement with other Attaching Entities to reimburse them for any costs that they incur in rearranging or transferring their facilities to accommodate Licensee's Attachments.

**7.6. Notification of Make Ready Work.** Before starting Make-Ready Work, Licensee shall notify all existing Attaching Entities of the date and location of the scheduled work and notify them of the need to rearrange and/or transfer their Facilities at Licensee's cost within the specified time period. To the extent that the City has the legal authority, it shall rearrange and/or transfer existing Facilities of such other Attaching Entities that have not been moved in a timely manner. Licensee shall pay the City's actual and documented costs for any such rearrangement or transfer.

**7.6.1.** In instances where Licensee is performing Make-Ready, where an existing Attaching Entity has not relocated or otherwise undertaken work required to complete Make-Ready (such as repairing existing Attachments not in compliance with Applicable Standards) within thirty (30) days of notice by the City or Licensee to such other Attaching Entity, Licensee is authorized, to the extent that the City has such authority, and the legal ability to delegate such authority, to relocate or repair the other Attaching Entity's Attachments on behalf of the City. Licensee shall pay the costs to relocate the other Attaching Entity's Attachments as part of Licensee's Make Ready.

**7.7. Licensee's Installation/Removal/Maintenance Work.**

**7.7.1.** All of Licensee's installation, removal, and maintenance work, by either Licensee's employees or authorized contractors, shall be performed at Licensee's sole cost and expense, in a good and workmanlike manner, and must not adversely affect the structural integrity of City Poles or other Facilities or other Attaching Entity's Facilities or equipment. All such work is subject to the insurance requirements of Article 25.

**7.7.2.** All of Licensee's installation, removal, and maintenance work, either by its employees or authorized contractors, shall comply with all applicable regulations specified in Article 4. Licensee shall assure that any person installing, maintaining, or removing its Cable Facilities is fully qualified and familiar with all Applicable Standards, the provisions of Article 24, and the Minimum Design Specifications contained in Appendix C.

**ARTICLE 8. POST-CONSTRUCTION INSPECTIONS.**

**8.1.** Within thirty (30) days of written notice to the City that the Licensee has completed installation of an Attachment including Overlash, Strand Mounted Wireless Facility, Riser Attachments, and/or Service Drops, the City or its contractors may perform a Post-Construction Inspection for each Attachment, Overlashing and/or installation made to City Poles. If such Post-Construction Inspections are performed, Licensee shall pay the actual and documented costs for the Post-Construction Inspection.

**8.2.** If the City elects to not perform any Post-Construction Inspection, such non-inspection shall not be grounds for any liability being imposed on the City or a waiver of any liability of Licensee.

**8.3.** If the Post-Construction Inspection reveals that Licensee's Facilities have been installed in violation of Applicable Standards or the approved design described in the Application, the City will notify Licensee in writing and Licensee shall have thirty (30) days from the date of receipt of such notice to Correct such violation(s), or such other period as the Parties may agree upon in



writing, unless such violation creates an Emergency in which case Licensee shall Correct such violation immediately. The City may perform subsequent Post-Construction Inspections within thirty (30) days of receiving notice that the Correction has been made as necessary to ensure Licensee's Attachments have been brought into compliance.

- 8.4. If Licensee's Attachments remain out of compliance with Applicable Standards or approved design after any subsequent inspection, consistent with Article 19, the City will provide notice of the continuing violation and Licensee will have thirty (30) days from receipt of such notice to Correct the violation, otherwise the provisions of Article 19 shall apply.

## **ARTICLE 9. INTENTIONALLY LEFT BLANK.**

## **ARTICLE 10. POLE REPLACEMENT AND REMOVAL.**

- 10.1. **Pole Replacement due to Emergency.** When there is an Emergency involving a Pole, and the City is made aware of the Emergency, the City will respond. The City will immediately secure the area as needed to ensure public safety. If the Pole in question is reasonably determined by the City to require replacement, the City will replace the Pole and transfer the City's attached Facilities. The City will make Licensee's and other Attaching Entities' Facilities safe and notify them to transfer their Facilities.
- 10.2. **Defective Pole Replacement for Licensee.** Where Licensee requires a Pole be replaced, and where Licensee is unable to place an Attachment on a Pole because such Pole is Defective, provided that the communications space on such Pole could not otherwise have been arranged with sufficient spacing to accommodate Licensee's proposed Attachment(s), the City may replace, at the City's sole cost, such Defective Pole. A "Defective Pole" means a Pole that is no longer serviceable due to decay, damage, or deterioration. This does not include any Pole replacement for Make Ready work.
- 10.3. **Pole Replacement for Non-Emergency.** Where Licensee requests the replacement of a Defective Pole, that does not pose an imminent threat or danger to safety or the safe functioning or operation of existing Attachments or Facilities, the City will replace said Pole, at its sole cost, consistent with its routine maintenance schedule.
- 10.4. **Expedited Pole Replacement for Licensee.** Except as provided in Paragraph 11.1, if Licensee seeks to expedite the replacement of a Defective Pole, a City contractor may replace the Pole and Licensee will pay the labor cost of an approved contractor(s) to replace the Pole.
- 10.5. **City Not Required to Replace.** Nothing in this Agreement shall be construed to require the City to replace any Pole for the benefit of Licensee.

## **ARTICLE 11. ALLOCATION OF COSTS.**

- 11.1. The costs for any rearrangement or transfer of Facilities or Pole replacement shall be allocated on the following basis:
- 11.1.1. If a Pole is modified or replaced, the City shall be responsible for the costs related to the modification or replacement of the Pole, unless the modification or replacement is requested by Licensee or another Attaching Entity. Each Party shall be responsible for transferring or rearranging their respective Attachments/Facilities and each Party shall

be responsible for their respective costs associated with the rearrangement or transfer of their respective Attachments/Facilities. Prior to making any such modification or replacement, when practical, the City shall provide Licensee written notification of its intent in order to provide Licensee a reasonable opportunity to modify or add to its existing Attachment(s). Should Licensee decide to do so, it must seek the City's written permission in accordance with this Agreement. If Licensee elects to add to or modify its Facilities on the replaced Pole, Licensee shall pay its share of any additional costs incurred by the City to make additional space on the replaced Pole accessible to Licensee.

**11.1.2.** If a Pole is modified or replaced at the request of Licensee, excluding modification or replacement due to routine maintenance, Licensee shall be responsible for all costs caused by the modification or replacement as well as the costs associated with the transfer or rearrangement of any other Attaching Entity's Facilities. As noted on the approved Permit, Licensee will notify any other Attaching Entity of such transfer or rearrangement. The City shall not be obligated in any way to enforce or administer Licensee's responsibility for the cost associated with the transfer or rearrangement of another Attaching Entity's Facilities pursuant to this Article.

**11.1.3.** If the modification or replacement of a Pole is the result of an additional Attachment or the modification of an existing Attachment sought by another Attaching Entity other than the City or Licensee, the Attaching Entity requesting the additional or modified Attachment shall bear the entire cost of the modification or replacement as well as the costs for rearranging or transferring Licensee's Facilities. Licensee shall cooperate with such third-party Attaching Entities to determine the costs of moving Licensee's Facilities and Licensee may require advance payment of its estimated costs prior to rearranging or transferring its Facilities.

**11.1.4.** If the Pole must be modified for reasons unrelated to the use of the Pole by Attaching Entities (e.g., storm, accident, deterioration), the City shall pay the costs of such modification and Licensee shall pay the costs of rearranging or transferring its Facilities.

**11.2. Transfer or Relocation of Licensee's Facilities.** Notwithstanding Article 10 and Article 11, the Parties may agree that in order to provide maximum flexibility in meeting in-service requirements and eliminating duplicative efforts, the City or a contractor mutually agreed to by the Parties, shall provide labor and equipment for Pole replacements, and the transfer, and/or relocation of Licensee's Facilities. Licensee shall pay the City or a mutually agreed to contractor for associated work.

## **ARTICLE 12. TREATMENT OF MULTIPLE REQUESTS FOR SAME POLE.**

If the City receives Permit Applications for the same Pole from two (2) or more prospective Attaching Entities within thirty (30) days of the initial request, and has not yet completed the Permitting of the initial Applicant, and accommodating their respective requests would require modification of the Pole or replacement of the Pole, the City will make reasonable and good faith efforts to allocate among such Attaching Entities the applicable costs associated with such modification or replacement.

## **ARTICLE 13. EQUIPMENT ATTACHMENTS.**

Equipment Attachments are not allowed on the pole and are not part of this Agreement.

## **ARTICLE 14. AUTHORIZED CONTRACTORS.**

If the City does not perform the Make Ready Work in or around the electric supply space, then Licensee shall only use authorized, qualified contractors approved by the City to conduct Make-Ready Work (or any other work) in or around the electric supply space on a Pole. The City shall not unreasonably withhold, delay, or condition its approval of any contractor proposed by Licensee to be authorized by the City to perform Make-Ready in the electric supply space on City Poles, provided such contractors meet the City's qualified contractor specifications.

## **ARTICLE 15. GUYS AND ANCHOR ATTACHMENTS.**

Licensee shall at its own cost and to the satisfaction of the City place guys and anchors to sustain any unbalanced loads caused by Licensee's Attachments. When, in unusual circumstances, Licensee determines that it is necessary or desirable for Licensee to attach its guys to anchors owned by the City, it may make Application to do so in a manner similar to that outlined in Article 6 above for Application to make Pole Attachments. In such circumstances, all the provisions of this Agreement that are applicable to Poles shall also be separately applicable to anchors. Licensee will be subject to a one-time Anchor Fee as set out in Appendix A but shall not be subject to an annual Attachment Fee for Licensee's use of anchors owned by the City. In the event that any anchor or guy to which Licensee desires to make Attachment to is inadequate to support the additional Facilities in accordance with the aforesaid specifications, the City will notify Licensee of the changes necessary to provide an adequate anchor or guy, together with the estimated cost thereof to Licensee. Licensee will compensate the City for the actual and documented cost including engineering and administrative cost for changing the guy and anchor if such change is performed by the City.

## **ARTICLE 16. INSTALLATION OF GROUNDS.**

When the City is requested by Licensee to install grounds or make connections to the City's system neutral, Licensee shall within thirty (30) days of demand, reimburse the City for the total actual and documented costs including engineering, clerical and administrative cost thereby incurred on initial installation only. All grounds installed by Licensee shall be in accordance with the City's standard grounding practices. In lieu of a documented cost, a fixed cost may be agreed upon, located in Appendix A.

## **ARTICLE 17. ABANDONMENT OF POLES.**

**17.1. Notice of Abandonment or Removal of City Facilities.** If the City desires at any time to abandon, remove, or underground any City Facilities to which Licensee's Cable Facilities are Attached, it shall give Licensee notice in writing to that effect at least sixty (60) days prior to the date on which it intends to abandon or remove such City Facilities. Notice may be limited to thirty (30) days if the City is required to remove or abandon its City Facilities as the result of the action of a third party and the lengthier notice period is not practical. If, following the expiration of the 60-day or 30-day period, as applicable, Licensee has not yet removed and/or transferred all of its Cable Facilities, the City shall have the right, but not the obligation, to remove or transfer Licensee's Cable Facilities at Licensee's expense and Licensee shall be subject to the provisions of Article 19. The City shall give Licensee prior written notice of any such removal or transfer of Licensee's Facilities.

**17.2. Underground Relocation.** If the City moves any portion of its aerial system underground, Licensee shall remove its Cable Facilities from any affected Poles within sixty (60) days, unless the Parties mutually agree to ninety (90) days, of receipt of notice from the City and must either relocate its affected Facilities underground with the City or find other means to accommodate its Facilities. If Licensee does not remove its Attachments within the applicable time period, the City shall have the right to remove or transfer Licensee's Cable Facilities at Licensee's expense, provided that the City or another Attaching Entity through action or inaction has not delayed Licensee's ability to complete such work. Licensee's failure to remove its Facilities as required under this Paragraph 17.2 shall subject Licensee to the provisions of Article 19, provided that the City or another Attaching Entity through action or inaction has not delayed Licensee's ability to complete such work.

## **ARTICLE 18. INSPECTIONS.**

**18.1. General Inspections.** The City reserves the right to make periodic inspections, as conditions may warrant, of the entire system of Licensee. Such inspections, or the failure to make such inspections, shall not operate to relieve Licensee of any responsibility or obligation or liability assumed under this Agreement.

**18.2. Periodic Safety Inspections.** Upon twelve (12) months advance written notice from the City, and not more frequently than every five (5) years, the City may at its option jointly perform a safety inspection in all or in part of the territory covered by this Agreement with all Attaching Entities to identify any safety violations of all Attachments and Facilities on City Poles or Facilities ("Safety Inspection"). Such notice shall describe the scope of the inspection and provide Licensee and all Attaching Entities an opportunity to participate. Regardless of whether Licensee chooses to participate, Licensee, City and other Attaching Entities shall share proportionately in the actual and documented Safety Inspection costs (based on the proportion of Attachments of the City and each other Attaching Entity) irrespective of whether the City elects to perform the Safety Inspection itself or have it performed by a contractor.

**18.3. Corrections.** In the event any of Licensee's Facilities are found to be in violation of the Applicable Standards and such violation poses a potential Emergency situation; Licensee shall use all reasonable efforts to Correct such violation immediately. Should Licensee fail or be unable to Correct such Emergency situation immediately, the City may Correct the Emergency and bill Licensee for one hundred twenty-five percent (125%) of the actual and documented costs incurred. If any of Licensee's Facilities placed after the Effective Date of this Agreement are found to be in violation of the Applicable Standards in effect at the time of initial construction or major upgrades and such violations do not pose potential Emergency conditions, the City shall, consistent with Article 19, give Licensee notice, whereupon Licensee shall have thirty (30) days from receipt of notice to Correct any such violation, or within a longer, mutually agreed to time frame if Correction of the violation is not possible within thirty (30) days, such extended time to be not more than an additional sixty (60) days. Notwithstanding the foregoing grace periods, in the event the City or another Attaching Entity prevents Licensee from Correcting a Non-Emergency violation, the timeframe for Correcting such violation shall be extended to account for the time during which Licensee was unable to Correct the violation due to action (or failure to act) by the City or another Attaching Entity. Licensee will not be responsible for the costs associated with violations caused by others that are not affiliated or acting under the direction of Licensee. In all circumstances, all of the Attaching Entities on the Pole and the City will work together to maximize safety while minimizing the cost of Correcting any such deficiencies, but the Licensee shall be responsible for the actual and documented cost of any necessary or



appropriate Corrective measures associated with violations caused by Licensee, including removal and replacement of the Pole and all transfers or other work incident thereto. If Licensee fails to Correct a non-Emergency violation within the specified time period, including any agreed upon extensions, the provisions of Article 19 shall apply.

- 18.3.1.** If any City Facilities are found to be in violation of the Applicable Standards and the City has caused the violation, then the Parties will work together to minimize the cost of Correcting any such deficiencies, but the City shall be responsible for the full cost of any necessary or appropriate Corrective measures, including removal and replacement of the Pole, provided, however, that the City shall not be responsible for Licensee's own costs.
- 18.3.2.** If one or more third-party Attaching Entity's Attachment caused the violation, then such Attaching Entities shall pay the Corrective costs incurred by all who have Attachments on the Pole, including the Licensee.
- 18.3.3.** If there exists a violation of Applicable Standards and it cannot be determined which Attaching Entity on the Pole caused such violation or there is a mixture of the Attaching Entities causing the violation, then the Parties will work together to minimize the cost of Correcting any such deficiencies, and all Attaching Entities who may have caused such violation will share equally in such costs.

#### **ARTICLE 19. FAILURE TO REARRANGE, TRANSFER OR CORRECT.**

- 19.1.** Unless otherwise agreed, as part of the City's written notice of a need for Licensee to rearrange, transfer, remove or Correct violations, the City will indicate whether or not the City is willing to perform the required work.
- 19.2.** If the City indicates in the notice that it is willing to perform the work, Licensee shall have fifteen (15) days to notify the City in writing of its election to either have the City perform the work or that the Licensee will perform the work itself.
  - 19.2.1.** If Licensee requests that the City perform the work, Licensee shall reimburse the City for the actual and documented cost of such work. If Licensee asks the City to perform the work and the City does not complete the work within the prescribed timeframe, Licensee can then perform the work itself. However, Licensee shall reimburse the City for the actual and documented costs for the portion of work the City did.
  - 19.2.2.** If Licensee either fails to respond or indicates that it will perform the work itself, and then does not complete the work within the prescribed time-frame, the City can invoke the Issue Resolution Process in Article 28 and the time intervals in Articles 28.3 and 28.4 shall each be reduced to thirty (30) days or the City can invoke the provisions of Article 19.2.3 and 19.2.4.
  - 19.2.3.** Notwithstanding Licensee's election under Article 19.2.2 to perform the required work itself, commencing on the thirtieth (30th) day after expiration of the time period for completion of the work specified in the Agreement and original notification, the City may perform the required work at Licensee's expense provided that the City or another Attaching Entity through action or inaction has not delayed Licensee's ability to complete such work.



**19.2.4.** Notwithstanding Licensee's election under Article 19.2.2, if Licensee was to perform work under this Article 19 and fails to perform such work within the specified timeframe, and the City performs or has performed such work, the City may charge Licensee an additional twenty-five percent (25%) of its actual and documented costs for completing such work, provided that the City or another Attaching Entity through action or inaction has not delayed Licensee's ability to complete such work.

**19.3.** If the City provides notice that it is unable to perform the work and Licensee fails to complete such work, then the City may on the thirtieth (30th) day after expiration of the time period for completion of the work specified in the agreement or original notification hire a qualified contractor to perform the work. The City may charge Licensee for its actual and documented contractor costs plus an additional twenty-five percent (25%).

**19.4.** Licensee shall provide written notification to the City upon completion of any of the required work. Notice of completion shall be given by the same means as it was received from the City.

## **ARTICLE 20. ACTUAL INVENTORY.**

**20.1.** The City may, at intervals of not more often than once every five (5) years, perform an actual inventory of the Attachments of Poles in all or in specific service areas of the territory covered by this Agreement, for the purpose of checking and verifying the number of Poles on which Licensee and other Attaching Entities have Attachments. Such field verification shall be made collectively by the City and all Attaching Entities, and the actual and documented cost shall be shared proportionately among all such Attaching Entities based upon the number of Attachments. Licensor shall provide at least thirty (30) days advance notice regarding the inventory and provide Licensee a reasonable opportunity to participate. Should a third-party contractor be selected to perform the inventory, the parties will mutually agree on the contractor selected and scope of work. However, if the parties are unable to agree within thirty (30) days, the City shall select the outside contractor to conduct the inventory, as well as the scope of work.

**20.2.** **Baseline Inventory.** The Parties mutually agree that the current Attachment Inventory will constitute the baseline inventory under this Agreement.

## **ARTICLE 21. UNAUTHORIZED ATTACHMENTS.**

If during the term of this Agreement, the City discovers Unauthorized Attachments placed on its Poles, the following fees may be assessed, and procedures will be followed:

**21.1.** The City shall provide specific written notice of each violation and Licensee shall be given thirty (30) days from receipt of notice to contest an allegation that an Attachment is unauthorized (or that Licensee failed to timely provide notice). The notice shall identify the precise location and a description of the Unauthorized Attachment.

**21.2.** Licensee shall pay back Fees for all Unauthorized Attachments for a period of five (5) years, or since the date of the last inventory of Licensee's Attachments (whichever period is shortest), at the amounts established in Appendix A.

**21.3.** In addition to the back Fees, for Facilities installed after the date of this Agreement, Licensee shall be subject to the Unauthorized Attachment Penalty as specified in Appendix A for each

Unauthorized Attachment, and Overlash or Strand Mounted Micro Wireless Facility installation where no Notification was provided, excluding Riser Attachments where an existing licensed Pole Attachment exists.

- 21.4.** Licensee shall submit a Permit Application or required Notification documentation in accordance with Article 6 of this Agreement within thirty (30) days of receipt of notice from the City of any Unauthorized Attachment, or such longer time as mutually agreed to by the Parties after an inventory.
- 21.4.1.** No additional notification is required for Riser Attachments where an existing licensed Pole Attachment exists.
- 21.4.2.** In the case of Overlash and/or Strand Mounted Micro Wireless Facility Notification requiring post installation documentation under Article 6.2, Licensee shall be required to submit the required Notification documentation within thirty (30) days of receipt of notice of Unauthorized Attachment for failure to Notify.
- 21.5.** In the event Licensee fails to submit a Permit Application within thirty (30) days, or such longer time as mutually agreed to by the parties after an inventory, the provisions of this Article (21.2, 21.3 and 21.4) shall apply.
- 21.6.** Notwithstanding anything to the contrary herein, if Licensee contests the allegation that an Attachment is unauthorized, then it shall not be considered unauthorized until the Parties resolve their dispute regarding its status pursuant to the Issue Resolution Process of Article 28.
- 21.7. No Ratification of Unauthorized Use.** No act or failure to act by the City with regard to any Unauthorized Attachments shall be deemed as ratification of the unauthorized use. Unless the parties agree otherwise, a Permit for a previously Unauthorized Attachment shall not operate retroactively or constitute a waiver by the City of any of its rights or privileges under this Agreement or otherwise, and Licensee shall remain subject to all obligations and liabilities arising out of or relating to its unauthorized use.

## **ARTICLE 22. ANNUAL REPORTING REQUIREMENTS.**

- 22.1.** At the time that Licensee pays its annual Attachment Fee, Licensee shall also provide the following information to the City, using the reporting form contained in Appendix D:
- 22.1.1.** The Poles on which Licensee has installed, during the relevant reporting period Risers for which no Permit was required.
- 22.1.2.** All Attachments that have become nonfunctional during the relevant reporting period. The report shall identify the Pole on which the nonfunctional Attachment is located, describe the nonfunctional equipment, and indicate the approximate date the Attachment became nonfunctional.
- 22.1.3.** Any equipment Licensee has removed from Poles during the relevant reporting period. The report shall identify the Pole from which the equipment was removed, describe the removed equipment, and indicate the approximate date of removal. This requirement does not apply where Licensee is surrendering a Permit.

22.1.4. In addition, Licensee shall furnish to the City annually an up-to-date electronic map depicting the locations of its Attachments, in a format agreed to by the City and an update of Appendix D. In lieu of this, Licensee will agree to accept the attachment records maintained by the City.

## **ARTICLE 23. LIABILITY AND INDEMNIFICATION.**

1.1. **Liability.** The City reserves to itself the right to maintain and operate its Poles in the manner that will best enable it to fulfill its service requirements. Licensee agrees that its use of City Poles is at Licensee's sole risk. Notwithstanding the foregoing, each Party shall exercise reasonable precautions to avoid damaging Facilities and shall report to the other Party the occurrence of any such damage caused by its employees, agents, contractors or subcontractors. Subject to Paragraph 23.6, the Parties agree to reimburse the other Party for all reasonable costs incurred by the other Party for the physical repair of Facilities damaged by the negligence or willful misconduct of either Party's employees, agents, contractors or subcontractors who caused said damage. Provided that the aggregate liability of City to Licensee, in any fiscal year of City, for such claims of physical damage to Licensee's Facilities shall not exceed the amount of the total Annual Attachment Fees paid by Licensee to the City for that year, as calculated based on the number of Attachments under Permit at the time of the occurrence, as set for in Appendix A.

1.2. **Indemnification.** Licensee and any agent, contractor, or subcontractor of Licensee, shall defend, indemnify, and hold harmless the City and its officials, officers, board members, council members, commissioners, representatives, employees, agents, and contractors against any and all liability, costs, damages, fines taxes, special charges by others, penalties, payments (including payments made by the City under any Workers' Compensation Laws or under any plan for employees' disability and death benefits), and expenses (including reasonable attorneys' fees of the City and all other costs and expenses of litigation) ("Covered Claims") arising in any way, including any act, omission, failure, negligence, or willful misconduct, in connection with the construction, maintenance, repair, presence, use, relocation, transfer, removal or operation by Licensee, or by Licensee's officers, directors, employees, agents, contractors, or subcontractors of Licensee's Communications Facilities, except to the extent of the City's negligence or willful misconduct solely giving rise to such Covered Claims. Such Covered Claims include, but are not limited to, the following:

1.2.1. Intellectual property infringement, libel and slander, trespass, unauthorized use of television or radio broadcast programs and other program material, and infringement of patents;

1.2.2. Cost of work performed by the City that was necessitated by Licensee's failure, or the failure of Licensee's officers, directors, employees, agents, contractors or subcontractors to install, maintain, use, transfer, or remove Licensee's Cable Facilities in accordance with the requirements and specifications of this Agreement, or from any other work this Agreement authorizes the City to perform on Licensee's behalf;

1.2.3. Damage to property, injury to or death of any person arising out of the performance or nonperformance of any work or obligation undertaken by Licensee, or Licensee's officers, directors, employees, agents, contractors, or subcontractors pursuant to this Agreement;

- 1.2.4. Liabilities incurred as a result of Licensee's violation, or a violation by Licensee's officers, directors, employees, agents, contractors or subcontractors of any law, rule, or regulation of the United States, any state, or any other governmental entity or administrative agency.

### 1.3. **Procedure for Indemnification.**

- 1.3.1. The City shall give prompt written notice to Licensee of any claim or threatened claim, specifying the factual basis for such claim and the amount of the claim, if known. If the claim relates to an action, suit, or proceeding filed by a third party against the City, the City shall give the notice to Licensee no later than fifteen (15) calendar days after the City receives written notice of the action, suit, or proceeding.
- 1.3.2. The City's failure to give the required notice will not relieve Licensee of its obligation to indemnify the City unless, and only to the extent, that Licensee is materially prejudiced by such failure.
- 1.3.3. Licensee will have the right at any time, by notice to the City to participate in or assume control of the defense of the claim with counsel of its choice, which counsel must be reasonably acceptable to the City. The City agrees to cooperate fully with indemnifying party Licensee. If Licensee assumes control of the defense of any third-party claim, the City shall have the right to participate in the defense at its own expense. If Licensee does not assume control or otherwise participate in the defense of any third-party claim, Licensee shall be bound by the results obtained by the City with respect to the claim.
- 1.3.4. If Licensee assumes the defense of a third-party claim as described above, then in no event will the City admit any liability with respect to, or settle, compromise or discharge, any third-party claim without Licensee's prior written consent.

### 1.4. **Fines and/or Penalties.**

- 1.4.1. Any fines, penalties or other costs incurred by either Party for non-compliance by such Party with the requirement of any law(s), rules(s), or regulation(s) shall be the sole responsibility of such non-complying Party.
- 1.4.2. If a Party is assessed such fines, penalties or other costs due to the non-compliance of the other Party, the non-complying Party shall indemnify and hold harmless the other Party against any and all losses, liabilities, damages and claims suffered or incurred because of the non-complying Party's non-compliance. The non-complying Party shall also reimburse the other Party for any and all legal or other expenses (including reasonable attorneys' fees) reasonably incurred by the other Party in connection with such losses, liabilities, damages and claims resulting from the non-complying Party's non-compliance.

- 1.5. **Environmental Hazards.** Licensee represents and warrants that its use of City Poles will not generate any Hazardous Substances, that it will not store or dispose on or about City Poles or transport to City Poles any hazardous substances and that Licensee's Cable Facilities will not constitute or contain and will not generate any hazardous substance in violation of federal, state, or local law now or hereafter in effect, including any amendments. "Hazardous Substance" shall be interpreted broadly to mean any substance or material designated or defined as hazardous



or toxic waste, hazardous or toxic material, hazardous or toxic or radioactive substance, unlawful radio frequency radiation, or other similar terms by any federal, state, or local laws, regulations or rules now or hereafter in effect, including any amendments. Licensee further represents and warrants that in the event of breakage, leakage, incineration, or other disaster, its Cable Facilities would not release any Hazardous Substances. Licensee and its agents, contractors, and subcontractors shall defend, indemnify, and hold harmless the City and its respective officials, officers, board members, council members, commissioners, representatives, employees, agents, and contractors against any and all liability, costs, damages, fines, taxes, special charges by others, penalties, punitive damages, or expenses (including reasonable attorneys' fees and all other costs and expenses of litigation) arising from or due to the release, threatened release, storage, or discovery of any Hazardous Substances on, under, or adjacent to the City's Poles/Conduit System attributable to Licensee's use of City Poles.

- 1.6. **No Consequential Damages.** NOTWITHSTANDING ANY OTHER PROVISION OF THIS AGREEMENT, NEITHER PARTY SHALL BE LIABLE TO THE OTHER FOR ANY CONSEQUENTIAL, INCIDENTAL, INDIRECT, LIQUIDATED, OR SPECIAL DAMAGES OR LOST REVENUE OR LOST PROFITS TO ANY PERSON ARISING OUT OF THIS AGREEMENT OR THE PERFORMANCE OR NONPERFORMANCE OF ANY PROVISION OF THIS AGREEMENT, EVEN IF SUCH PARTY HAS BEEN INFORMED OF THE POSSIBILITY OF SUCH DAMAGES.
- 1.7. **Municipal Liability Limits.** No provision of this Agreement is intended, or shall be construed, to be a waiver for any purpose by the City of any applicable state limits on municipal liability or governmental immunity. No indemnification provision contained in this Agreement under which Licensee indemnifies the City shall be construed in any way to limit any other indemnification provision contained in this Agreement.

#### **ARTICLE 24. DUTIES, RESPONSIBILITIES, AND EXCULPATION.**

- 24.1. **Duty to Inspect.** Licensee acknowledges and agrees that the City does not warrant the condition or safety of City Facilities, or the premises surrounding the Facilities, and Licensee further acknowledges and agrees that it has an obligation to inspect City Poles or premises surrounding the Poles, prior to the commencement of any work on City Poles or entering the premises surrounding such Poles.
- 24.2. **Knowledge of Work Conditions.** By executing this Agreement, Licensee warrants that it has acquainted, or will fully acquaint, itself and its employees and/or contractors and agents with the conditions relating to the work that Licensee will undertake under this Agreement and that it fully understands or will acquaint itself with the Facilities, difficulties, and restrictions attending the execution of such work.
- 24.3. **DISCLAIMER.** THE CITY MAKES NO EXPRESS OR IMPLIED WARRANTIES WITH REGARD TO CITY POLES OR FACILITIES, ALL OF WHICH ARE HEREBY DISCLAIMED, AND THE CITY MAKES NO OTHER EXPRESS OR IMPLIED WARRANTIES, EXCEPT TO THE EXTENT EXPRESSLY AND UNAMBIGUOUSLY SET FORTH IN THIS AGREEMENT. THE CITY EXPRESSLY DISCLAIMS ANY IMPLIED WARRANTIES OF MERCHANTABILITY OR FITNESS FOR A PARTICULAR PURPOSE.
- 24.4. **Duty of Competent Supervision and Performance.** The Parties further understand and agree that, in the performance of work under this Agreement, Licensee and its agents, employees,



contractors, and subcontractors will work near electrically energized lines, transformers, or other City Facilities. The Parties understand and intend that energy generated, stored, or transported by City Facilities will not be interrupted during the continuance of this Agreement, except in Emergencies endangering life or threatening grave personal injury or property. Licensee shall ensure that its employees, agents, contractors, and subcontractors have the necessary qualifications, skill, knowledge, training, and experience to protect themselves, their fellow employees, agents, contractors, and subcontractors; employees, agents, contractors, and subcontractors of the City; and the general public, from harm or injury while performing work permitted pursuant to this Agreement. In addition, Licensee shall furnish its employees, agents, contractors, and subcontractors competent supervision and sufficient and adequate tools and equipment for their work to be performed in a safe manner. Licensee agrees that in emergency situations in which it may be necessary to de-energize any part of the City's equipment, Licensee shall ensure that work is suspended until the equipment has been de-energized and that no such work is conducted unless and until the equipment is made safe.

- 24.5. Requests to De-energize.** If the City de-energizes any equipment or line at Licensee's request and for its benefit and convenience in performing a particular segment of any work, Licensee shall reimburse the City in accordance with Article 3.8, for all costs and expenses that the City incurs in complying with Licensee's request. Before the City de-energizes any equipment or line, it shall provide, upon request, an estimate of all costs and expenses to be incurred in accommodating Licensee's request.
- 24.6. Interruption of Service.** If Licensee causes an interruption of service by damaging or interfering with any equipment of the City, Licensee shall, at its own expense, immediately do all things reasonable to avoid injury or damages, direct and incidental, resulting therefrom and shall notify the City immediately.
- 24.7. Duty to Inform.** Licensee further warrants that it understands the imminent dangers (INCLUDING SERIOUS BODILY INJURY OR DEATH FROM ELECTROCUTION) inherent in the work necessary to make installations on City Poles by Licensee's employees, agents, contractors, or subcontractors, and Licensee accepts the duty and sole responsibility to notify and inform Licensee's employees, agents, contractors, or subcontractors of such dangers, and to keep them informed regarding same.

## **ARTICLE 25. INSURANCE.**

- 25.1. Policies Required.** At all times during the term of this Agreement, the Licensee shall keep in force and effect all insurance policies as described in this Article.
- 25.2. Licensee Insurance.** Licensee certifies that it self-insures for and/or maintains the following insurance coverages:
- 25.2.1. Workers' Compensation and Employers' Liability Insurance.** Statutory workers' compensation benefits and employers' liability insurance with a limit of liability no less than that required by Missouri law at the time of the application of this provision for each accident. Licensee shall require subcontractors and others not protected under its insurance to obtain and maintain such insurance.
- 25.2.2. Commercial General Liability Insurance.** Licensee's self-insurance and/or insurance policy provides coverage for, but not limited to, the following: premises and operations,

products and completed operations, personal injury, blanket contractual coverage, property damage, independent contractor's coverage with Limits of liability not less than \$2,000,000 general aggregate, \$2,000,000 products/completed operations aggregate, \$2,000,000 personal injury, \$2,000,000 each occurrence.

**25.2.3. Automobile Liability Insurance.** Licensee's business automobile self-insurance and/or insurance policy covers all owned, hired and non-owned private passenger autos and commercial vehicles, with bodily injury limits of \$1,000,000 for each person and \$1,000,000 for each accident and with property damage limits of \$1,000,000 for each accident.

**25.2.4. Umbrella Liability Insurance.** In addition to Licensee's self-insurance and other insurance coverage, Licensee will maintain umbrella liability insurance coverage in excess of the sum of employers' liability, commercial general liability, and automobile liability insurance coverages required above. Limits of liability not less than \$4,000,000 each occurrence and \$4,000,000 aggregate. Overall limits of liability may be met through any combination of self-insurance, primary and excess liability policies.

**25.2.5. Property Insurance.** Each party will be responsible for maintaining property insurance or self-insurance on its own Facilities, buildings, and other improvements, including all equipment, fixtures, and utility structures, fencing, or support systems that may be placed on, within, or around City Facilities to protect fully against hazards of fire, vandalism and malicious mischief, and such other perils as are covered by policies of insurance commonly referred to and known as "extended coverage" insurance or self-insure such exposures.

**25.3. Qualification; Priority; Contractors' Coverage.** The insurer must be authorized to do business under the laws of the state of Missouri and have an "A-" or better rating in Best's Guide. Such insurance will be primary. All contractors and subcontractors who perform work on behalf of Licensee shall carry, in full force and effect, workers' compensation and employers' liability, commercial general liability, and automobile liability insurance coverages of the type that Licensee is required to obtain under this Article 25 with the same limits.

**25.4. Certificate of Insurance; Other Requirements.** Licensee may self-insure all or a portion of the insurance coverage and limit requirements of this Agreement. Licensee shall provide to the City evidence sufficient to demonstrate its financial ability to self-insure the insurance coverage limits required by this Agreement, provided that such financial ability shall be deemed sufficient as long as Licensee maintains a Standard and Poor's bond rating of A- or better. For all non-self-insured coverages, Licensee shall provide the City with a certificate of insurance ("Certificate"), prior to the execution of this Agreement and prior to each insurance policy expiration date during the term of this Agreement. Licensee will provide the City with excerpts from its insurance policies that are relevant to a denied claim should one arise but reserves the right to redact confidential information. The City shall be given thirty (30) calendar days advance notice of cancellation or nonrenewal of insurance during the term of this Agreement. The City, its council members, board members, commissioners, agencies, officers, officials, employees and representatives (collectively, "Additional Insureds") shall be named as Additional Insureds under all the commercial general liability, automobile liability, and umbrella liability policies, which shall be so stated on the Certificate of Insurance. All policies, other than workers' compensation, shall be written on an occurrence and not on a claims-made basis. Licensee shall defend, indemnify and hold harmless the City and Additional Insureds from and against payment of any deductible

and payment of any premium on any policy required under this Article. Licensee shall obtain Certificates from its contractors and their subcontractors and provide a copy of such Certificates to the City upon request.

- 25.5. Limits.** The limits of liability set out in this Article 25 may be increased or decreased by mutual consent of the Parties, which consent will not be unreasonably withheld by either Party, in the event of any factors or occurrences, including substantial increases in the level of jury verdicts or judgments or the passage of state, federal, or other governmental compensation plans, or laws that would materially increase or decrease Licensee's exposure to risk.
- 25.6. Prohibited Exclusions.** The Commercial General Liability Policy required to be obtained by Licensee or its contractors or subcontractors shall not contain provisions that: (1) exclude coverage of liability assumed by this Agreement with the City except as to infringement of patents or copyrights or for libel and slander in program material, (2) exclude coverage of liability arising from excavating, collapse, or underground work, (3) exclude coverage for injuries to City employees or contractors, or (4) exclude coverage of liability for injuries or damages caused by Licensee's contractors or the contractors' employees, or agents to the extent that Licensee is responsible for the liability under this Agreement. This list of prohibited provisions shall not be interpreted as exclusive.
- 25.7. Deductible/Self-insurance Retention Amounts.** Licensee shall be fully responsible for any deductible or self-insured retention amounts contained in its insurance program or for any deficiencies in the amounts of insurance maintained.

## **ARTICLE 26. ASSIGNMENT.**

- 26.1. Limitations on Assignment.** Neither this Agreement nor any part of Licensee's rights hereto may be assigned or pledged, in whole or in part, without the express written consent of the City, which consent shall not be unreasonably withheld, conditioned, or delayed.
- 26.1.1.** Notwithstanding the foregoing, the transfer of the rights and obligations of Licensee under this Agreement to a parent, subsidiary, successor, or financially viable affiliate, or to any entity which acquires all or substantially all of Licensee's assets by reason of a merger, acquisition or other business reorganization, shall not be deemed an assignment for the purposes of this Agreement, provided that:
- 26.1.1.1.** Licensee furnishes the City thirty (30) days prior written notice of the transfer or assignment, together with the name and address of the transferee or assignee and;
  - 26.1.1.2.** Provided that Licensee delivers to the City the following: (1) a Bond issued in the name of the transferee; (2) an Assignment and Assumption agreement between the City and the transferee; (3) the transferee's Certificate of Insurance naming the City as insured; and (4) a copy of this Agreement with an Addendum whereby transferee has become a signatory to this Agreement assuming all obligations of Licensee arising under this Agreement.
  - 26.1.1.3.** Notwithstanding any assignment or transfer, Licensee shall remain fully liable under this Agreement and shall not be released from performing

any of the terms, covenants, or conditions of this Agreement without the express written consent to the release of Licensee by the City.

**26.2. Prohibition on Sub-licensing.** Except as provided by Appendix E of this Agreement, Licensee shall not sub-license to any third party, including but not limited to, allowing third parties to place Wireless Facilities on City Poles or Facilities, including Overlapping or Strand Mounted Micro Wireless Facilities, or to place Attachments for the benefit of such third parties on City Poles. Any such action shall constitute a material breach of this Agreement. The use of Licensee's Cable Facilities or Strand Mounted Micro Wireless Facilities by third parties, including but not limited to leases of dark fiber, which involves no additional Attachment or Overlapping, is not subject to this Article 26.2.

**26.2.1.** However, as provided by Appendix E of this Agreement, this restriction on sub-licensing, does not apply to and is not intended to prevent third parties from using Licensee's Strand Mounted Micro Wireless Facilities or Services, provided proper Notice pursuant to this Agreement has been provided by Licensee. Licensee shall ensure that such use by any third parties complies with this Agreement. Licensee remains responsible and liable for all performance obligations under this Agreement with respect to such use by third parties of Licensee's Strand Mounted Micro Wireless Facilities. The City's sole point of contact regarding such third parties' use and activities shall be Licensee.

#### **ARTICLE 27. FAILURE TO ENFORCE.**

Failure of the City or Licensee to take action to enforce compliance with any of the terms or conditions of this Agreement or to give notice or declare this Agreement or any authorization granted hereunder terminated shall not constitute a waiver or relinquishment of any term or condition of this Agreement, but the same shall be and remain at all times in full force and effect until terminated, in accordance with this Agreement.

#### **ARTICLE 28. ISSUE RESOLUTION PROCESS.**

**28.1. Dispute Resolution.** Except for an action seeking a temporary restraining order or an injunction or to compel compliance with this dispute resolution procedure, the Parties shall invoke the dispute resolution procedures in this Article to resolve a controversy, claim, or breach arising under this Agreement. Each Party will bear its own costs for dispute resolution activity.

**28.2. Initial Meeting.** At either Party's written request, each Party will designate knowledgeable, responsible, senior representatives to meet and negotiate in good faith to resolve a dispute. The representatives will have discretion to decide the format, frequency, duration, and conclusion of these discussions. The Parties will conduct any meeting in-person or via conference call, as reasonably appropriate.

**28.3. Executive Meeting.** If ninety (90) days after the first in-person meeting of the senior representatives, referenced in 28.2, the Parties have not resolved the dispute to their mutual satisfaction, each Party will designate executive representatives at the director level or above to meet and negotiate in good faith to resolve the dispute. To facilitate the negotiations, the Parties may agree in writing to use mediation or another alternative dispute resolution procedure.

**28.3.1.** The Parties regard the aforesaid obligation, to escalate to an executive-level, in-person meeting, as an essential and material provision of this Agreement and one that is legally



binding upon them. If such Executive Meeting is not engaged in, either Party may seek to specifically enforce this obligation in the courts having jurisdiction hereunder.

- 28.4. Unresolved Dispute.** If after sixty (60) days from the first executive-level, in-person meeting, the Parties have not resolved the dispute to their mutual satisfaction; either Party may invoke any legal means available to resolve the dispute, including enforcement of the default and termination procedures set out in Article 29.
- 28.5. Confidential Settlement.** Unless the Parties otherwise agree in writing, and to the extent that such communication is considered confidential under Missouri law, communication between the Parties under this Article will be treated as confidential information developed for settlement purposes, exempt from discovery and inadmissible in litigation.
- 28.6. Business as Usual.** During any dispute resolution procedure or lawsuit, the Parties will continue providing services to each other and performing their obligations under this Agreement.
- 28.7. Fees and/or Penalties.** Fees and penalties will continue to accrue pending dispute resolution procedures unless the dispute specifically involves a dispute over the application of the fee or penalty.

#### **ARTICLE 29. DEFAULT.**

- 29.1.** An Event of Default (each of the following being an "Event of Default") shall be deemed to have occurred hereunder by Licensee if:
- 29.1.1.** Licensee breaches any material term or condition of this Agreement or Permit granted hereunder; or
  - 29.1.2.** Licensee evades or attempts to evade any material provision of this Agreement or Permit granted hereunder; or
  - 29.1.3.** Licensee makes a material misrepresentation of fact in this Agreement or Permit granted hereunder; or
  - 29.1.4.** Licensee fails to complete work by the date and in accordance with the terms specified in this Agreement or Permit granted hereunder, unless an extension is obtained or unless the failure to complete the work is beyond the Licensee's control or the result of a Force Majeure Event; or
  - 29.1.5.** Licensee fails to timely Correct violations of Applicable Standards.
- 29.2.** Upon the occurrence of any one or more of the Events of Default set forth in Article 29 hereof, the City, at its option, in addition to and not in lieu of any other remedies provided for herein, shall be entitled to proceed to exercise any and all actions it may have in law or at equity, including drawing down upon the bond for any fees, costs, expenses or penalties that Licensee has not paid, and, in addition, at its option, may terminate this Agreement upon providing notice to Licensee, provided, however, the City may take such action or actions only after first giving Licensee reasonable written notice of the Event of Default and a reasonable time in which Licensee may cure or commence diligent efforts to cure such Event of Default, which period of time shall be not less than sixty (60) days, except that the period of time shall not be less than

twenty (20) days for monies past due and owing by Licensee to City; for failure to maintain adequate insurance, as provided for herein; and for failure to maintain any bonds required pursuant to this Agreement.

- 29.3.** Without limiting the rights granted to the City pursuant to the foregoing Article 29.2, the parties hereto agree to conduct themselves reasonably and in good faith and to use a good faith effort to meet and to resolve outstanding issues, including but not limited to the Dispute Resolution Process of Article 28.
- 29.4.** In the event the City fails to perform, observe or meet any material covenant or condition made in this Agreement or shall breach any material term of condition of this Agreement, or at any time any representation, warrant or statement made by officials or employees of the City who have actual requisite authority to make such representations, warranties or statements and such representations, warranties or statements shall be incorrect or misleading in any material respect, then the City shall be in default of this Agreement. Upon being provided notice from Licensee of said default, the City shall have thirty (30) days to cure same and if such default is not cured, then Licensee shall have all remedies at law or in equity available to it, including termination of this Agreement without any liability therefor.
- 29.4.1.** The above Paragraph 29.4 notwithstanding, Licensee's sole remedy if the City is unable to perform a survey or complete Make-Ready Work within the prescribed timeframes under Articles 6 and 7 is the authority to perform such survey or Make Ready itself at Licensee's expense, except any work in the electric supply space which must be done by the City or a contractor approved by the City. The City will provide, upon request, a list of contractors approved to perform surveys or Make-Ready Work. Licensee may perform such survey or Make Ready Work itself or, for work in the electric supply space, retain a City approved contractor immediately upon expiration of the prescribed time frames without any cure period or Issue Resolution Process. The City will approve additional contractors submitted by Licensee to the extent that they are qualified to perform the relevant work in accordance with the Applicable Standards.
- 29.4.2.** Under no circumstances will the failure of the City to meet the survey or Make Ready time periods set out in Article 7 subject the City to damages.
- 29.5.** Upon Termination of the entire Agreement for Default as provided for in Paragraph 29.2, Licensee shall remove its Attachments from all City Poles within twelve (12) months of the notice, or at a rate of one thousand (1,000) Attachments per month, whichever period results in the greatest length of time for completing removal. The Parties agree that the time period will be extended for Licensee if permit requests by Licensee to install new poles to transfer its Attachments or permit requests to underground its Facilities are not being timely processed for reasons outside the control of the Parties. If, after six months, Licensee is not on pace to complete removal of all of its Attachments by the end of the specified time period (including applicable extensions) or, after the specified time period (including applicable extensions) has elapsed, Licensee has not removed all of its Attachments; the City shall have the right, without need for further dispute resolution efforts to remove Licensee's Attachments, and Licensee agrees to pay the actual and documented cost thereof within forty-five (45) days after it has received an invoice from the City. If applicable state or federal law provides that Licensee has a right to attach to City Poles, then both Parties shall in good faith negotiate rates, terms and conditions of a new Pole Attachment Agreement, but such negotiations shall not relieve either Party of their obligations to remove Attachments as set forth above.

## **ARTICLE 30. RECEIVERSHIP, FORECLOSURE OR ACT OF BANKRUPTCY.**

- 30.1.** The Pole use granted hereunder to Licensee shall, at the option of the City, cease and terminate one hundred twenty (120) days after the filing of bankruptcy or the appointment of a receiver or receivers or trustee or trustees to take over and conduct the business of Licensee whether in a receivership, reorganization, bankruptcy or other action or proceeding unless such receivership or trusteeship shall have been vacated prior to the expiration of said one hundred twenty (120) days, or unless such receivers or trustees shall have, within one hundred twenty (120) days after their election or appointment, fully complied with all the terms and provisions of this Agreement granted pursuant hereto, and the receivers or trustees within said one hundred twenty (120) days shall have remedied all Defaults under this Agreement.
- 30.2.** In the case of foreclosure or other judicial sale of the property and equipment of Licensee, or any part thereof, including or excluding this Agreement, the City may serve notice of termination upon Licensee and the successful bidder at such sale, in which event this Agreement herein granted and all rights and privileges of this Agreement hereunder shall cease and terminate thirty (30) days after service of such notice, unless:
- 30.2.1.** The City shall have approved the transfer of this Agreement to the successful bidder, as and in the manner in this Agreement provided; and
- 30.2.2.** Such successful bidder shall have covenanted and agreed with the City to assume and be bound by all the terms and conditions to this Agreement.

## **ARTICLE 31. REMOVAL OF ATTACHMENTS.**

Licensee may at any time remove its Attachments from any City Facility but shall promptly give the City written notice of such removals. No refund of any fee will be due on account of such removal.

## **ARTICLE 32. PERFORMANCE BOND.**

Licensee shall furnish a performance bond executed by a surety company reasonably acceptable to the City which is duly authorized to do business in the state of Missouri in the amount of fifty thousand dollars (\$50,000.00) for the duration of this Agreement as security for the faithful performance of this Agreement and for the payment of all persons performing labor and furnishing materials in connection with this Agreement.

## **ARTICLE 33. TERM OF AGREEMENT.**

- 33.1.** This Agreement shall become effective upon its execution and, if not terminated in accordance with other provisions of this Agreement, shall continue in effect for a term of five years and, unless terminated by either Party, shall automatically be renewed for subsequent additional 1 year terms. Either Party may terminate this Agreement at the end of the initial term or a successor term by giving written notice of intent to terminate the Agreement at the end of the then-current term. Such a notice must be given at least ninety (90) days prior to the end of the then-current term.

**33.2.** Even after the termination of this Agreement, Licensee's indemnity obligations shall continue with respect to any claims or demands related to Licensee's Cable Facilities, as provided for in Article 23.

**ARTICLE 34. AMENDING AGREEMENT.**

This Agreement shall not be amended, changed, or altered except in writing and with approval by authorized representatives of both Parties.

**ARTICLE 35. NOTICES.**

**35.1.** Wherever in this Agreement notice is required to be given by either Party to the other, such notice shall be in writing and shall be effective when personally delivered to, or when mailed by certified mail with return receipt requested, with postage prepaid, and except where specifically provided for elsewhere, properly addressed as follows:

If to City, at:

ATTN: Director of Public Works and Utilities  
Address: PO Box 395, Nixa, MO 65714  
Phone: 417.725.3785

With a Copy to:

ATTN: City Attorney  
Address: P.O. Box 395, Nixa, MO 65714  
Phone: 417.725.3785

If to Licensee, at:

ATTN: Chris Harness  
Address: 1091 W Kathryn St Nixa, MO 65714  
Phone: 417-851-1107

or to such other address as either Party, from time to time, may give the other Party in writing.

**35.2.** The above notwithstanding, the parties may agree to utilize electronic communications such as, for NJUNS notifications, as well as email for notifications related to the Permits application and approval process and necessary transfer or pole modifications.

**35.3.** Licensee shall maintain a staffed 24-hour emergency telephone number, not available to the general public, where the City can contact Licensee to report damage to Licensee's Facilities or other situations requiring immediate communications between the Parties. Such contact person shall be qualified and able to respond to the City's concerns and requests regarding this Agreement. Failure to maintain an emergency contact shall subject Licensee to a penalty of \$100 per incident and shall eliminate the City's liability to Licensee for any actions that the City deems reasonably necessary given the specific circumstances.

**ARTICLE 36. ENTIRE AGREEMENT.**



This Agreement and its Appendices constitute the entire Agreement between the Parties concerning Attachments of Licensee's Cable Facilities on City Poles within the geographical service area covered by this Agreement. Unless otherwise expressly stated in this Agreement, all previous agreements, whether written or oral, between the City and Licensee are superseded and of no further effect.

#### **ARTICLE 37. SEVERABILITY.**

If any provision or portion thereof of this Agreement is or becomes invalid under any applicable statute or rule of law, such provision shall not render unenforceable this entire Agreement. Rather, the Parties intend that the remaining provisions shall be administered as if the Agreement did not include the invalid provision.

#### **ARTICLE 38. GOVERNING LAW.**

All matters relating to this Agreement shall be governed by the laws (without reference to choice of law) of the state of Missouri.

#### **ARTICLE 39. INCORPORATION OF RECITAL AND APPENDICES.**

The recitals stated above and all Appendices to this Agreement are incorporated into and constitute part of this Agreement.

#### **ARTICLE 40. FORCE MAJEURE.**

If either the City or Licensee is prevented or delayed from fulfilling any term or provision of this Agreement by reason of fire, flood, earthquake, or like acts of nature, wars, revolution, civil commotion, explosion, acts of terrorism, embargo, acts of the government in its sovereign capacity, material changes of laws or regulations, labor difficulties, including without limitation, strikes, slowdowns, picketing or boycotts, unavailability of equipment of vendor, or any other such cause not attributable to the negligence or fault of the Party delayed in performing the acts required by the Agreement, then performance of such acts shall be excused for the period of the unavoidable delay, and the affected Party shall endeavor to remove or overcome such inability as soon as reasonably possible.

#### **ARTICLE 41. NONDISCRIMINATORY TREATMENT.**

In accordance with RSMo. § 67.5104.2, City shall be nondiscriminatory between all Pole Attachers and will not act more favorably or less favorably between such Pole Attachers in the assessment of fees, rates, terms, or conditions of this Agreement.

#### **ARTICLE 42. MUTUAL RESERVATION OF RIGHTS.**

Nothing in this Agreement shall be deemed a waiver by City or Licensee of the rights of each such party under applicable law, rules and regulations, including without limitation the right to seek judicial or administrative review of the provisions of this Agreement. City reserves and in no way waives any right to enforce the requirements in this Agreement during the term of this Agreement and Licensee agrees to such reservation and non-waiver by City. Licensee reserves and in no way waives any right to challenge the enforcement of the fees, terms and conditions in this Agreement, including without limitation under the provisions of RSMo § 67.5104, and City agrees to such reservation and non-waiver by Licensee.

IN WITNESS WHEREOF, the parties have set their hands on the day and year herein stated.

THE CITY OF NIXA, MISSOURI

TOTAL HIGHSPEED, LLC

\_\_\_\_\_  
Jimmy Liles, City Administrator

\_\_\_\_\_  
*Renea Hohenfeldt*

\_\_\_\_\_  
*Renea Hohenfeldt*

Printed Name

Date: \_\_\_\_\_

\_\_\_\_\_  
CEO

Title

ATTEST:

Date: 11-8-24

\_\_\_\_\_  
Rebekka Coffey, City Clerk

Approved as to form:

\_\_\_\_\_  
Nick Woodman, City Attorney

Director of Finance Certification:

I certify that this contract is within the purpose of the appropriation to which it is to be charged and that there is an unencumbered balance to the credit of such appropriation sufficient to pay therefore, and that the appropriate accounting entries have been made.

\_\_\_\_\_  
Jennifer Evans, Director of Finance

LICENSEE VERIFICATION

STATE OF MISSOURI    )  
                                  ) ss  
COUNTY OF CHRISTIAN )

On this 8<sup>th</sup> day of November, 2024, before me personally appeared Renea Hohenfeldt, for Licensee, known to me to be the person described in and who executed the above agreement and acknowledged to me that they executed the same as their free act and deed on behalf of said entity.

IN TESTIMONY WHEREOF, I have hereunto set my hand and affixed my official seal in the county and state aforesaid, the day and year first above written.

\_\_\_\_\_  
*Kelly-Jean Burk*  
Notary Public

My commission expires: 5/29/2028

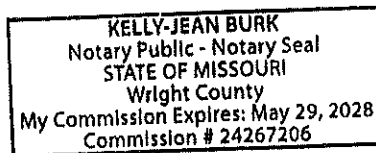

## APPENDIX A—FEES and CHARGES

The Annual Pole Attachment Fee: Eleven dollars and fourteen cents (\$11.14) per Attachment per year.

Consistent with Article 3 of the Agreement, the Annual Pole Attachment Fee shall be calculated on an annual basis and be consistent with Missouri Revised Statutes Section 67.5104.

Each Attachment shall only occupy twelve (12) inches of vertical space on a Pole, as measured either above or below (but not both) the point of attachment, and any Attachment outside of the twelve inches shall be deemed to constitute a separate Attachment for Pole Attachment Fee calculation purposes.

### Non-Recurring Fees<sup>1</sup>

1. License Application Fee: One-hundred dollars (\$100.00) per Application (limit 50 attachments per Application).
2. Make Ready Work and Other Charges: See Article 3 of Agreement.
3. Work performed by Utility where Licensee failed to perform in a timely manner may be subject to a twenty-five percent (25%) additional charge pursuant to Article 19 of Agreement.
4. Anchor Use Fee: One-time fee of Two hundred dollars (\$200.00) per Utility Anchor.

### Penalties

1. Standard Unauthorized Attachment Penalty Fee:

One hundred dollars (\$100) per Attachment (including Service Drops, and Riser Attachments that were not reported).

2. Non-Transfer/Removal Penalty:

If, consistent with Article 19 of the Agreement, Licensee fails to rearrange, transfer, remove or Connect violations in a timely manner, Licensee shall be subject to a daily penalty of five dollars (\$5.00) per Attachment, per day beginning on the day after expiration of the original time period for completion of the work specified in the Agreement and the original notification that Operator needs to Rearrange, Transfer, Remove or Correct Violations. Beginning with the ninetieth (90<sup>th</sup>) calendar day after expiration of the time period for completion of the work specified in the Agreement and original notification the daily penalty shall escalate to ten dollars (\$10.00) per Attachment per day.

---

<sup>1</sup> City reserves the right to adjust non-recurring fees from time to time to cover actual costs, provided any such adjustment is applied on a nondiscriminatory basis to all Attaching Entities.

## **APPENDIX B—Pole Attachment Permit Application Process**

The following procedure is to be followed by each Licensee seeking to make new Attachments on Utility's Poles, or overlash to existing cables attached on Utility's Poles. Note that no entity may make any Attachments to Utility's Poles or overlash to existing facilities on Utility's Poles without having first entered into a binding Pole Attachment Licensing Agreement with Utility. Third parties seeking to overlash to an existing cable attached to Utility's Pole must also have a written overlash agreement with the Pole Attachment owner to be overlashed. The overlash agreement must be provided to the Utility at the time of application for overlash.

1. Licensee shall submit a written request to perform a Pre-Construction Inspection. The request must include a preliminary route description. Licensee shall have a professional engineer or utility-approved employee or contractor, participate in a Pre-Construction Inspection, which will include a review of the proposed Attachment(s) to determine the feasibility of the request and identify any potential Make-Ready Work. Appendix F to this Agreement contains the minimum design review information that an applicant must provide and a worksheet for determining the minimum specifications that the proposed Attachment must meet.
2. Following the Pre-Construction Inspection, Licensee shall submit a completed Permit Application (Appendix C) that includes: route map, information required in Appendix F, installation plans, recommendations on Make-Ready Work, and a pole-loading analysis stamped by a licensed professional engineer. Licensee shall prepare the Permit Application in adherence with the Applicable Standards (Section 1.2 of Agreement) and specifications (Appendix D).
3. At the Licensee's expense, the Utility will review the recommendations from the inspection and the pole-loading analysis, and discuss any issues with the Licensee. Utility may utilize a contractor to perform or assist in the analysis and review.
4. Upon receipt of written authorization, Utility (or its approved contractors) will proceed with Make-Ready Work according to the specific agreed-upon installation plans and the terms of the Agreement, including payment for the Make-Ready Work charges as set out by Utility and agreed to by the Licensee.
5. Upon completion of the Make-Ready Work, the Utility will *sign* and return the Application for Permit authorizing the Licensee to make its Attachment(s) in accordance with agreed-upon installation plans.



6. Within thirty (30) days of completing the installation of an Attachment (including Overlash, Riser Attachments, and/or Service Drops) Licensee shall provide written notice to Utility.
  
7. Unless waived in writing by the Utility, the Licensee's professional engineer, utility-approved employee, or contractor shall submit written certification that he/she has completed the Post-Construction Inspection and that the installation was done in accordance with the provisions of the Permit. The Post-Construction Inspection shall be submitted within ninety (90) calendar days after receipt of notice that the installation is complete. The Utility will verify the inspection by means that it deems to be reasonable.

# APPENDIX C - Application for Permit

Application Date: \_\_\_\_\_

To: [Insert Address of Utility Permitting Department]

Desire to: \_\_\_\_\_ Attach to Utility Pole(s)  
                  \_\_\_\_\_ Remove from Utility Pole(s)  
                  \_\_\_\_\_ Overlash to existing facility attached to Utility Pole(s)

Permit No. \_\_\_\_\_ Superseded Permit No. \_\_\_\_\_

Number of Poles this permit Sheet 1 of \_\_\_\_\_

Licensee Name: \_\_\_\_\_

Address: \_\_\_\_\_

Contact Person: \_\_\_\_\_ Phone \_\_\_\_\_

Title: \_\_\_\_\_

Utility Contact Person: \_\_\_\_\_ Phone \_\_\_\_\_

Title: \_\_\_\_\_

Narrative of proposed activity:

In accordance with the terms and conditions of the Pole Attachment Licensing Agreement between the parties, application is hereby made for a Permit to attach to and/or vacate Pole(s) in the locations detailed on the attached Route Map(s). Also, attached is documentation as required by Appendix F of the Agreement. If applicable, the engineer's name, state registration number, and phone number are:

Name: \_\_\_\_\_ Phone \_\_\_\_\_

Registration # \_\_\_\_\_

Permission is hereby granted to Licensee to attach and/or vacate poles listed on the attached Field Data Summary Sheets, subject to payment of the necessary Make-Ready Work charges as set out by Utility and agreed to by the Licensee.

SUBMITTED:

APPROVED:

Licensee \_\_\_\_\_

For Nixa Utilities

By \_\_\_\_\_

By \_\_\_\_\_

Title \_\_\_\_\_

Title \_\_\_\_\_

Date \_\_\_\_\_

Date \_\_\_\_\_

GENERAL POLE ATTACHMENT STANDARDS INDEX

GENERAL POLE ATTACHMENT STANDARDS

A proposed tenant requesting to attach to Nixa owned poles or overlash existing facilities owned by the proposed tenant or another tenant on Nixa poles must first have an existing Pole Attachment Agreement or Joint Use Agreement in place with Nixa. Every proposed attachment or overlash must first be approved by Nixa. An application for approval shall be submitted to Nixa that follows the requirements of the corresponding Agreement with the requesting tenant.

The requesting tenant must submit along with each application the required information listed in the section below. All planning costs associated with the request will be the responsibility of the tenant requesting the pole attachment or overlash.

Any existing attachment or overlash without an approved attachment or overlash request shall be considered an unauthorized attachment and subject to a penalty as determined by the related attachment agreement.

POLE ATTACHMENT AND OVERLASH APPLICATION PROCEDURES

A pole attachment and/or overlash application shall include the following:

1. The attachment application required by the corresponding Pole Attachment or Joint Use Agreement.
2. The number of poles per request will be limited to the number indicated in the corresponding attachment agreement.
3. One set of marked up maps showing the streets, addresses and pole locations of designated poles with Nixa pole numbers.
4. A pole loading analysis of each pole in the application using a finite element analysis program such as PLS-Pole, (Power Line Systems Inc.) or an Nixa approved equivalent program to calculate pole loading as required by the related Agreement. The analysis shall be done using NESC Grade C construction requirements and with .5 inch ice and 41b./ft<sup>2</sup> wind loading. The analysis shall be approved by Nixa Engineering Department.
5. Identify any overloaded poles and any "make ready work" necessary to meet these attachment standards and correct any existing violations.
6. Detailed drawings of the proposed attachments indicating size, weight and location of attachment.
7. Nixa will determine if there will be any cost related to the attachment request. Any related costs will be paid in advance before work will begin.

GENERAL REQUIREMENTS

Use of equipment brackets, standoffs, crossarms, extension arms and davit arms are not allowed. Poles shall not be boxed in. Communication cable shall not be installed on opposite sides of a pole.

Tenants are responsible for their own down guys and anchors designed to meet the NESC requirements. Attachment to Nixa anchors require a submitted request and prior approval.

Proof of required easements shall be provided upon request.

All vertical runs installed by tenant shall be placed in conduit and attached to pole using a minimum of 6" standoff brackets. U-guard and other protective covering are prohibited. Location of tenant risers shall be in accordance with Nixa standards.



**GENERAL POLE ATTACHMENT STANDARDS INDEX**

**STANDARD NUMBER**



## GENERAL POLE ATTACHMENT STANDARDS INDEX

### WIRELESS ATTACHMENT DEVICES

Only one wireless device (receiver, transmitter or combination unit) less than 6x12x4 inches will be allowed per pole. Only one wireless provider will be permitted on a single pole.

Only one wireless device may be attached to a streetlight bracket arm. The unit must be no more than 3 feet and no less than 6 inches from the pole. Maximum weight of the device shall not exceed 151 lbs. when installed on a street light arm.

When wireless equipment is installed above the communication space, it must be installed by Nixa or a Nixa approved contractor that is qualified to work in the supply space.

Nixa may deny any attachment request or allow with the exception to reserve pole space for any planned future Nixa installation.

### SUPPLY AND COMMUNICATIONS

Amplifiers and equipment other than wireless devices will not be allowed on Nixa poles. All communication devices requiring power shall have a disconnect switch, located on a separate meter stand. This will enable Nixa to disconnect power to the antennae and the battery backup, to avoid RF exposure to its employees while working around the devices. See attached standards.

A Nixa new service application shall be required to provide equipment power. Installation shall follow current Nixa Service Standards.

### POLE TOP ANTENNA

1. The design and mounting requirements of all antennas must be approved by Nixa Engineering Department prior to installation.
2. Only one antenna shall be installed per pole.
3. The antenna must be installed by Nixa or a Nixa approved contractor that is qualified to work in the Supply Space.
4. No work shall be completed in the Supply Space without approval of the Nixa Engineering Department.
5. All poles must be bucket truck accessible.
6. Pole Top Antenna will only be allowed on Distribution or Street Light Poles.
7. Antenna shall only be allowed on tangent poles.
8. Antenna shall not be installed on equipment poles or in the Primary Zone on a pole.
9. The height of all distribution poles used to mount pole top antennas shall be increased by 5 feet above existing pole height.
10. The use of pole top extensions is prohibited.
11. Antenna coax cable shall be installed in maximum size 2 inch diameter Sch. 40 PVC conduit. Conduit supports should be installed every 5 feet. Conduit less than 1 inch may be attached to the pole with ground wire molding staples.
12. When required, two RF warning signs must be installed. One sign shall be installed near the pole top at the level where the safe approach level ends and for FCC General Population/uncontrolled power levels. The second sign shall be installed near the base of the pole. These signs shall say "Warning - antenna safe approach distance is [xx] feet" and the antenna owners name and phone number. When Nixa work is required within the antenna approach distance, workers will disconnect the RF power source.
13. The antenna power source shall have a lockable disconnect installed to allow the antenna and battery backup to be de-energized when required for safety.
14. Disconnect, meter and antenna equipment must be installed in accordance with the current Nixa Construction Standards.
15. A driven pole ground is required for each antenna installation. It shall be installed to meet Nixa Construction Standards.
16. If a pole with communications equipment installed needs to be replaced, NJUNS will be used to notify the attaching companies to relocate their equipment.



## GENERAL POLE ATTACHMENT STANDARDS INDEX

STANDARD  
NUMBER  
GPAS

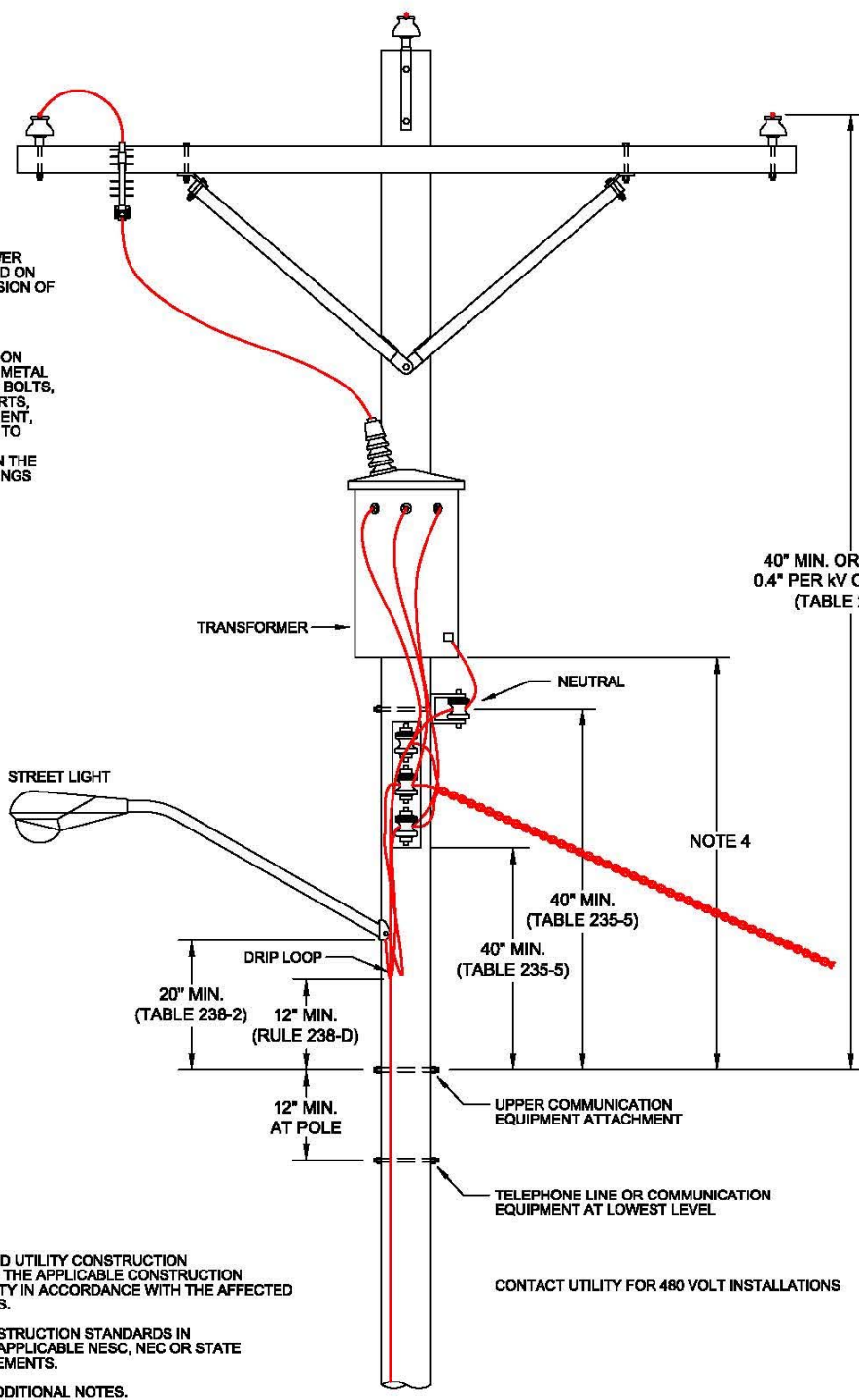

NO COMMUNICATIONS POWER SUPPLY SHALL BE MOUNTED ON POLES EXCEPT BY PERMISSION OF UTILITY.

LICENSEE'S ATTACHMENTS ON UTILITY POLES, INCLUDING METAL ATTACHMENT CLAMPS AND BOLTS, METAL CROSS ARM SUPPORTS, BOLTS AND OTHER EQUIPMENT, MUST BE ATTACHED SO AS TO MAINTAIN THE MINIMUM SEPARATIONS SPECIFIED IN THE NESC AND IN THESE DRAWINGS AND SPECIFICATIONS.

40" MIN. OR 40" PLUS 0.4" PER kV OVER 8.7kV (TABLE 235-5)

TRANSFORMER

NEUTRAL

STREET LIGHT

NOTE 4

40" MIN. (TABLE 235-5)

40" MIN. (TABLE 235-5)

20" MIN. (TABLE 238-2)

12" MIN. (RULE 238-D)

12" MIN. AT POLE

UPPER COMMUNICATION EQUIPMENT ATTACHMENT

TELEPHONE LINE OR COMMUNICATION EQUIPMENT AT LOWEST LEVEL

120/240V SERVICE DROP WITH EFFECTIVELY GROUNDED MESSENGER. (RULE 235-C2b1)

CONTACT UTILITY FOR 480 VOLT INSTALLATIONS

**NOTES:**

1. REFER TO THE ATTACHED UTILITY CONSTRUCTION STANDARDS, OR OBTAIN THE APPLICABLE CONSTRUCTION STANDARDS FROM UTILITY IN ACCORDANCE WITH THE AFFECTED UTILITY'S REQUIREMENTS.
2. APPLY THE UTILITY CONSTRUCTION STANDARDS IN COORDINATION OF THE APPLICABLE NESC, NEC OR STATE STATUTE CODE REQUIREMENTS.
3. SEE DRAWING 02 FOR ADDITIONAL NOTES.
4. UTILITY CONSTRUCTION STANDARD DOES NOT ALLOW TRANSFORMER TANK TO BE LOWER THAN SYSTEM NEUTRAL OR SECONDARY.



**CITY OF NIXA**  
CHRISTIAN COUNTY, MO  
NIXA UTILITIES  
Count on us.

DATE: 01/01/19

REVISED:

# OVERHEAD MINIMUM CLEARANCES

STANDARD NUMBER  
A-01

1

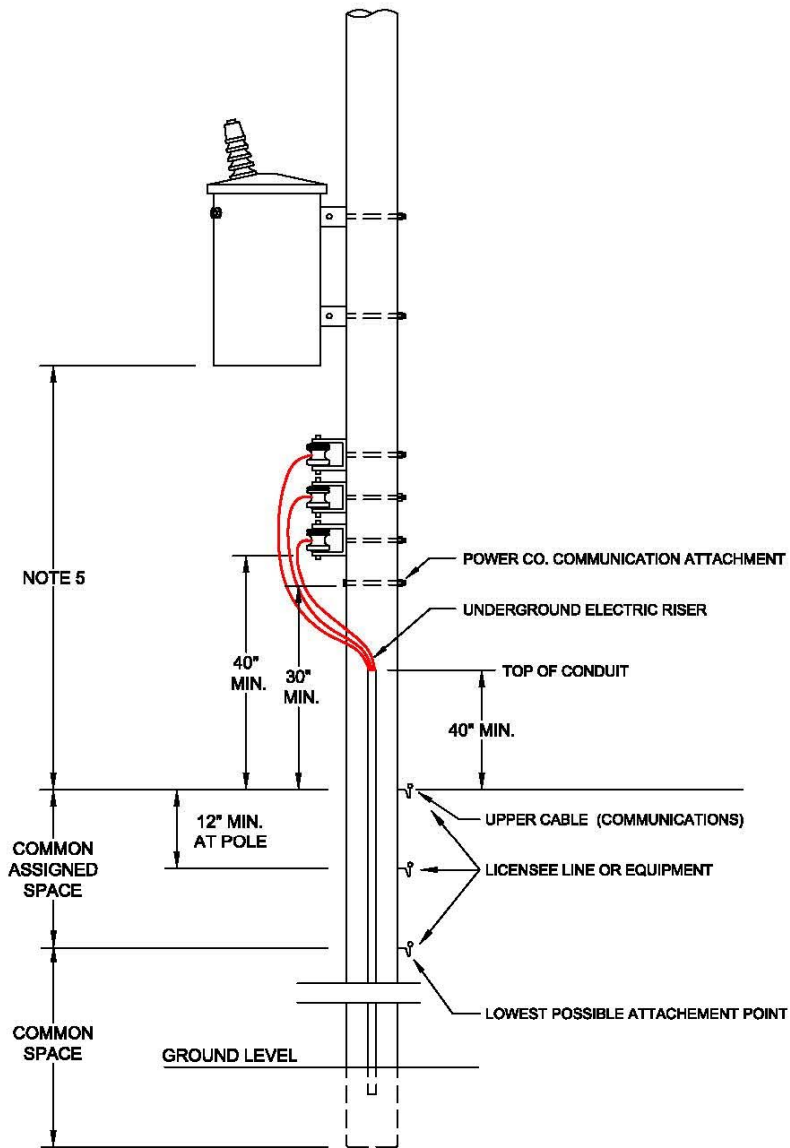

**NOTES:**

1. SEPARATION BETWEEN VERTICAL RUNS AND ANY METAL PARTS OR THROUGH BOLTS OF POWER OR COMMUNICATION EQUIPMENT SHALL BE AT LEAST 2" IN ANY DIRECTION. BOLTS SHALL HAVE LESS THAN 2" EXPOSED THREAD.
2. NO COMMUNICATIONS POWER SUPPLY SHALL BE MOUNTED ON POLES EXCEPT BY PERMISSION OF THE UTILITY.
3. THE ABOVE CLEARANCES MAY HAVE TO BE INCREASED TO ALLOW FOR CODE CLEARANCE REQUIREMENT IN MID SPAN.
4. LICENSEE'S ATTACHMENTS ON UTILITY POLES, INCLUDING METAL ATTACHMENT CLAMPS AND BOLTS, METAL CROSS ARM SUPPORTS, BOLTS AND OTHER EQUIPMENT, MUST BE ATTACHED SO AS TO MAINTAIN THE MINIMUM SEPARATIONS SPECIFIED IN THE NESC AND IN THESE DRAWINGS AND SPECIFICATIONS.
5. UTILITY CONSTRUCTION STANDARD DOES NOT ALLOW TRANSFORMER TANK TO BE LOWER THAN SYSTEM NEUTRAL OR SECONDARY.

**CITY OF NIXA**  
**UTILITIES**  
 ✓ Count on us.

DATE: 01/01/19

REVISED:

# OVERHEAD MINIMUM CLEARANCES

STANDARD  
 NUMBER  
 A-02

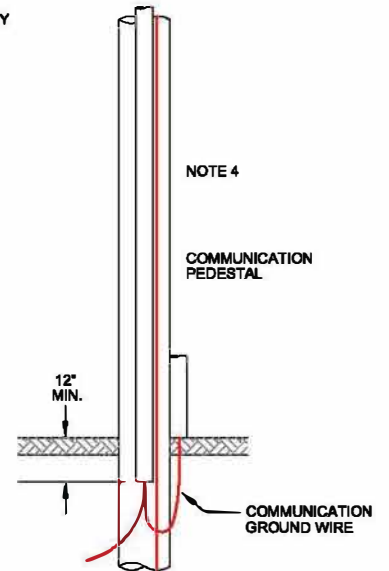
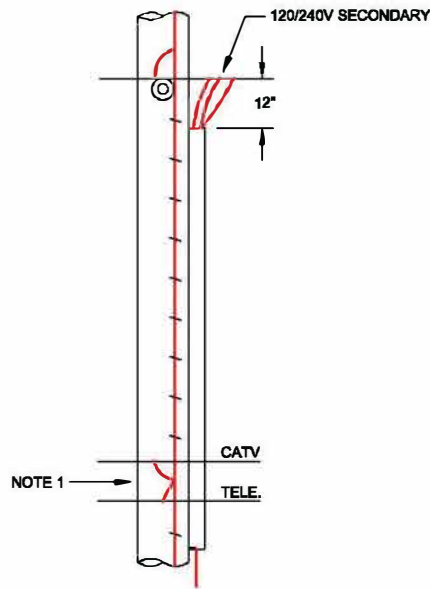
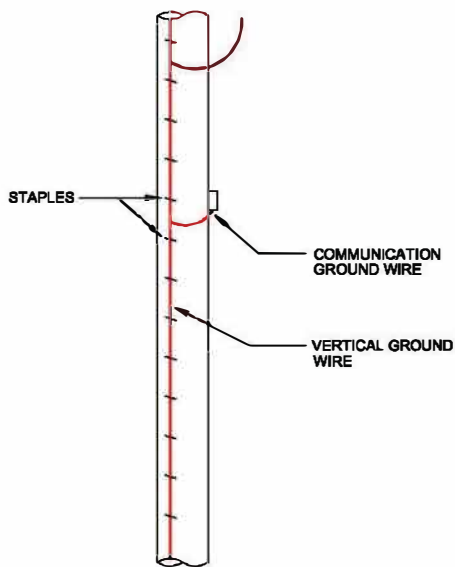

NO COMMUNICATIONS POWER SUPPLY SHALL BE MOUNTED ON POLES EXCEPT BY PERMISSION OF UTILITY.

LICENSEE'S ATTACHMENTS ON UTILITY POLES, INCLUDING METAL ATTACHMENT CLAMPS AND BOLTS, METAL CROSS ARM SUPPORTS, BOLTS AND OTHER EQUIPMENT, MUST BE ATTACHED SO AS TO MAINTAIN THE MINIMUM SEPARATIONS SPECIFIED IN THE NESC AND IN THESE DRAWINGS AND SPECIFICATIONS.

**NOTES:**

1. LICENSEE SHALL BOND TO UTILITY POLE GROUND WHEREVER UTILITY HAS A DOWN GROUND ON THE POLE. IF THE GROUND IS UNDER THE METAL U-GUARD, CONTACT UTILITY TO MAKE THE GROUND CONNECTION.
2. IF NO POLE GROUND EXISTS CONTACT UTILITY TO HAVE POLE GROUND INSTALLED.
3. BOND WIRE SHALL BE #6 BARE COPPER OR LARGER. IF BOND WIRE IS UNSUPPORTED FOR MORE THAN 12" LONG, STAPLE TO POLE.
4. WHEN COMMUNICATIONS ARE UNDERGROUND, THE POWER IS OVERHEAD AND IT IS REQUIRED THAT THE COMMUNICATIONS GROUND BE INTERCONNECTED TO THE POWER SUPPLY GROUND, THE CONNECTION SHALL BE MADE BELOW GRADE.
5. IN NO CASE SHALL LICENSEE GROUND BE CONNECTED TO GUYS/ANCHORS.
6. IF A NEUTRAL ISOLATION DEVICE IS INSTALLED ON THIS POLE THE ATTACHER MUST CONTACT UTILITY FOR SPECIAL GROUNDING INSTRUCTIONS.
7. LICENSEE'S MESSENGER CABLE SHALL BE BONDED TO UTILITY'S POLE GROUND WIRE AT EACH POLE THAT HAS A GROUND WIRE.



DATE: 01/01/19

REVISED:

## GROUNDING CONNECTIONS

3

STANDARD  
NUMBER  
A-03



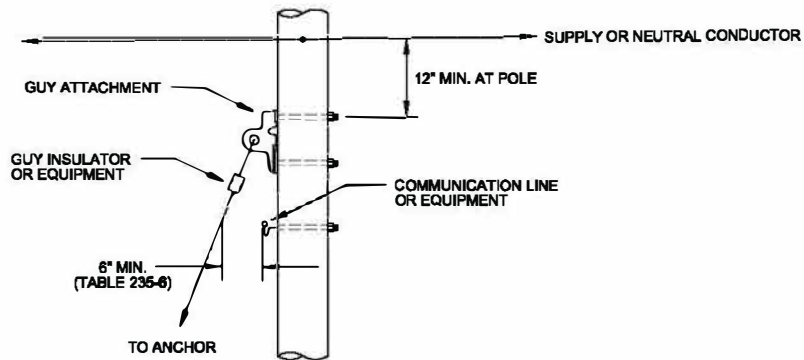

**INSULATED GUY OPTION**

**CONTACT UTILITY TO DETERMINE IF GUYS ARE TO BE INSULATED OR GROUNDED.**

**NOTES:**

1. LICENSEE SHALL BE RESPONSIBLE FOR PROCURING AND INSTALLING ALL ANCHORS AND GUY WIRES TO SUPPORT THE ADDITIONAL STRESS PLACED ON THE UTILITY'S POLES BY LICENSEE'S ATTACHMENTS.
2. ANCHORS AND GUY WIRES MUST BE SET ON EACH UTILITY POLE WHERE THERE IS A TURN OR ANGLE AND ON ALL DEAD-END UTILITY POLES.
3. LICENSEE MAY NOT PLACE GUY WIRES ON THE ANCHORS OF UTILITY OR THIRD PARTY USER WITHOUT PRIOR WRITTEN CONSENT OF ALL ATTACHING ENTITIES AND ANCHOR OWNERS.
4. NO ATTACHMENT MAY BE INSTALLED ON A UTILITY POLE UNTIL ALL REQUIRED GUYS AND ANCHORS ARE INSTALLED, NOR MAY ANY ATTACHMENT BE MODIFIED OR RELOCATED IN SUCH A WAY AS WILL MATERIALLY INCREASE THE STRESS OR LOADING ON UTILITY POLES UNTIL ALL REQUIRED GUYS AND ANCHORS ARE INSTALLED.
5. LICENSEE'S DOWN GUYS SHALL NOT BE BONDED TO GROUND OR NEUTRAL WIRE OF UTILITY'S POLE AND SHALL NOT PROVIDE A CURRENT PATH TO GROUND FROM THE POLE GROUND OR POWER SYSTEM NEUTRAL.
6. ON JOINTLY USED STRUCTURES, GUYS THAT PASS WITHIN 12" OF SUPPLY CONDUCTORS AND ALSO PASS WITHIN 12" OF COMMUNICATION CABLES, SHALL BE PROTECTED WITH A SINGLE INSULATED COVERING WHERE THE GUY PASSES THE SUPPLY CONDUCTORS, UNLESS THE GUY IS EFFECTIVELY GROUNDED OR INSULATED WITH A STRAIN INSULATOR AT A POINT BELOW THE LOWEST SUPPLY CONDUCTOR AND ABOVE THE HIGHEST COMMUNICATION CABLE.

NO COMMUNICATIONS POWER SUPPLY SHALL BE MOUNTED ON POLES EXCEPT BY PERMISSION OF UTILITY.

LICENSEE'S ATTACHMENTS ON UTILITY POLES, INCLUDING METAL ATTACHMENT CLAMPS AND BOLTS, METAL CROSS ARM SUPPORTS, BOLTS AND OTHER EQUIPMENT, MUST BE ATTACHED SO AS TO MAINTAIN THE MINIMUM SEPARATIONS SPECIFIED IN THE NESC AND IN THESE DRAWINGS AND SPECIFICATIONS.



DATE: 01/01/19

REVISED:

## GUY WIRE REQUIREMENTS

STANDARD  
NUMBER  
A-04

4

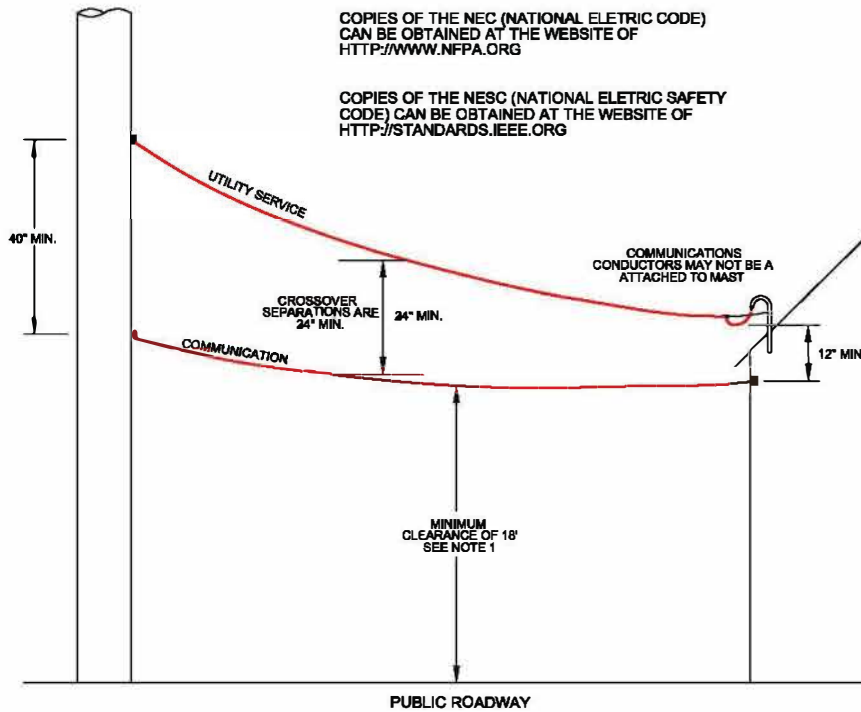

NOTES: (THE NESC CHANGES EVERY THREE YEARS. THE CLEARANCES NOTED BELOW HAVE LIMITING CONDITIONS AND MAY CHANGE. REFER TO SECTION 232 OF THE NESC FOR LATEST REQUIREMENTS.)

NO COMMUNICATIONS POWER SUPPLY SHALL BE MOUNTED ON POLES EXCEPT BY PERMISSION OF THE UTILITY.

1. MAINTAIN MINIMUM CLEARANCE
  - A) RAILROADS - 24'
  - B) INTERSTATE, MODOT - 18'
  - B) DRIVEWAYS - 18'
  - B) WALKWAYS - 12'
2. REFERENCE NESC CLEARANCES ON SAME SUPPORTING STRUCTURES
  - A) SECTION 235
  - B) SECTION 238
3. REFERENCE NESC CLEARANCES ON DIFFERENT SUPPORTING STRUCTURES
  - A) SECTION 233

LICENSEE'S ATTACHMENTS ON UTILITY POLES, INCLUDING METAL ATTACHMENT CLAMPS AND BOLTS, METAL CROSS ARM SUPPORTS, BOLTS AND OTHER EQUIPMENT, MUST BE ATTACHED SO AS TO MAINTAIN THE MINIMUM SEPARATIONS SPECIFIED IN NESC AND IN THESE DRAWINGS AND SPECIFICATIONS.



DATE: 01/01/19

REVISED:

## MINIMUM CLEARANCE TO SERVICE AND ROADWAY

STANDARD NUMBER  
A-06

6

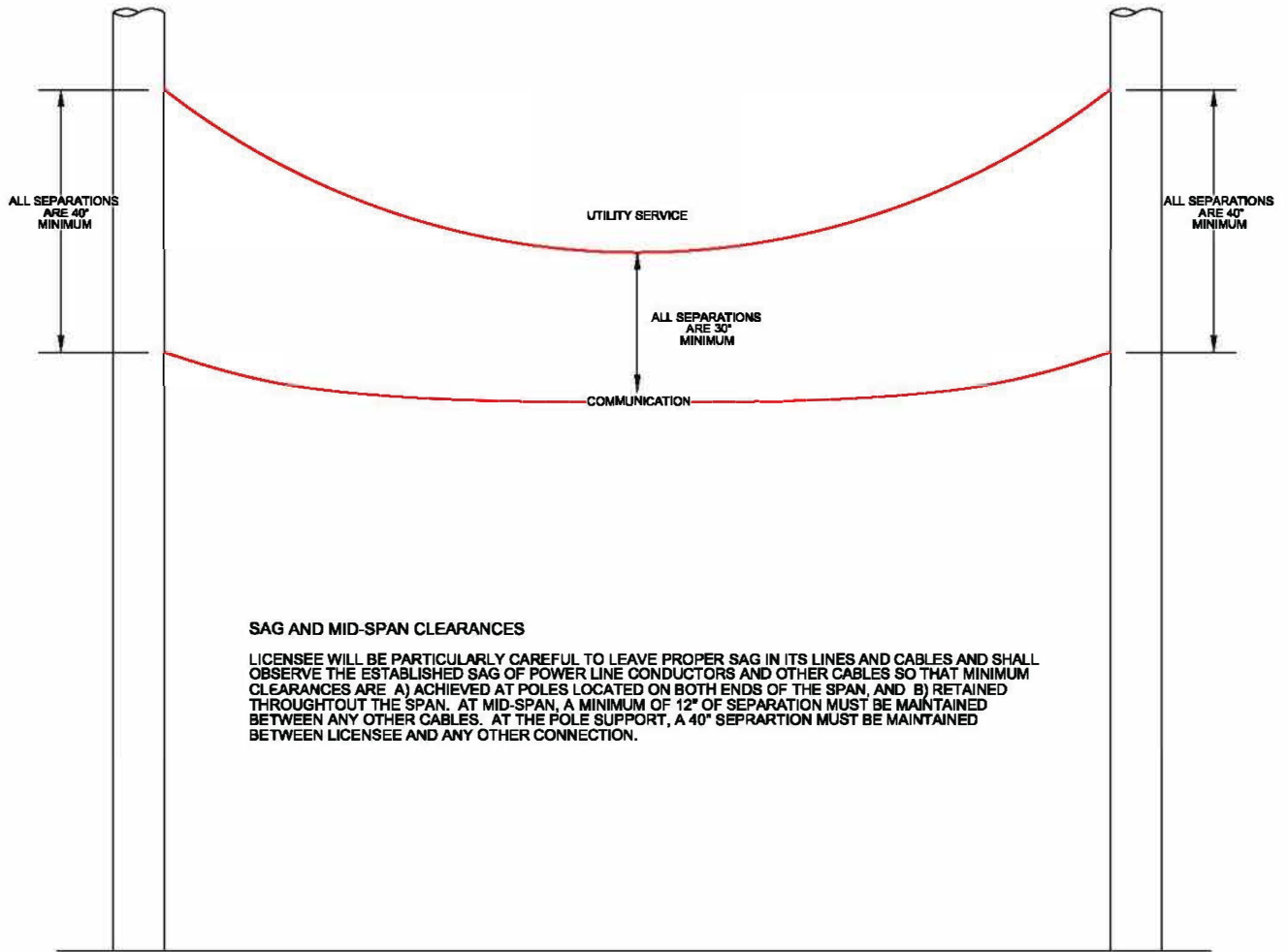

**SAG AND MID-SPAN CLEARANCES**

LICENSEE WILL BE PARTICULARLY CAREFUL TO LEAVE PROPER SAG IN ITS LINES AND CABLES AND SHALL OBSERVE THE ESTABLISHED SAG OF POWER LINE CONDUCTORS AND OTHER CABLES SO THAT MINIMUM CLEARANCES ARE A) ACHIEVED AT POLES LOCATED ON BOTH ENDS OF THE SPAN, AND B) RETAINED THROUGHOUT THE SPAN. AT MID-SPAN, A MINIMUM OF 12" OF SEPARATION MUST BE MAINTAINED BETWEEN ANY OTHER CABLES. AT THE POLE SUPPORT, A 40" SEPARATION MUST BE MAINTAINED BETWEEN LICENSEE AND ANY OTHER CONNECTION.

COPIES OF THE NEC (NATIONAL ELECTRIC CODE) CAN BE OBTAINED AT THE WEBSITE OF [HTTP://WWW.NFPA.ORG](http://www.nfpa.org)

COPIES OF THE NESC (NATIONAL ELECTRIC SAFETY CODE) CAN BE OBTAINED AT THE WEBSITE OF [HTTP://STANDARDS.IEEE.ORG](http://standards.ieee.org)

NO COMMUNICATIONS POWER SUPPLY SHALL BE MOUNTED ON POLES EXCEPT BY PERMISSION OF THE UTILITY.

LICENSEE'S ATTACHMENTS ON UTILITY POLES, INCLUDING METAL ATTACHMENT CLAMPS AND BOLTS, METAL CROSS ARM SUPPORTS, BOLTS AND OTHER EQUIPMENT, MUST BE ATTACHED SO AS TO MAINTAIN THE MINIMUM SEPARATIONS SPECIFIED IN NESC AND IN THESE DRAWINGS AND SPECIFICATIONS.



DATE: 01/01/19

REVISED:

**MINIMUM CLEARANCE BETWEEN CIRCUITS**

7

**STANDARD NUMBER  
A-07**

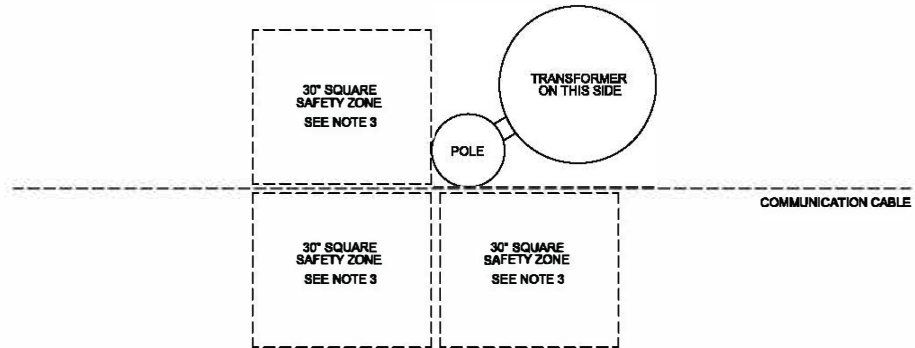

**NOTES:**

1. FOR NEW CABLE INSTALLATIONS LOCATE CABLE ON THE SAME SIDE OF THE POLE AS UTILITY'S LOWEST CONDUCTOR.
2. STANDOFF BRACKETS TO MOUNT CABLE TO POLE ARE NOT ALLOWED WITHOUT APPROVAL OF UTILITY.
3. CLIMBING AND WORKSPACE THROUGH THE COMMUNICATION SPACE SHALL EXTEND FROM 40" BELOW THE LOWEST COMMUNICATION CABLE TO THE TOP OF THE POLE.
4. ON TRANSFORMER POLES THE COMMUNICATION SERVICE DROPS SHALL BE LOCATED SO THAT THEY ORIGINATE FROM THE MESSENGER ON THE SIDE OF THE POLE OPPOSITE THE TRANSFORMER.
5. MINIMUM CLEARANCES FOR CLIMBING AND WORKING SPACE SHALL BE FOLLOWED AS PER NESC SECTION 236.

NO COMMUNICATIONS POWER SUPPLY SHALL BE MOUNTED ON POLES EXCEPT BY PERMISSION OF THE UTILITY.

LICENSEE'S ATTACHMENTS ON UTILITY POLES, INCLUDING METAL ATTACHMENT CLAMPS AND BOLTS, METAL CROSS ARM SUPPORTS, BOLTS AND OTHER EQUIPMENT, MUST BE ATTACHED SO AS TO MAINTAIN THE MINIMUM SEPARATIONS SPECIFIED IN NESC AND IN THESE DRAWINGS AND SPECIFICATIONS.



DATE: 01/01/19

REVISED:

## CLIMBING SPACE REQUIREMENTS

8

STANDARD  
NUMBER  
A-08

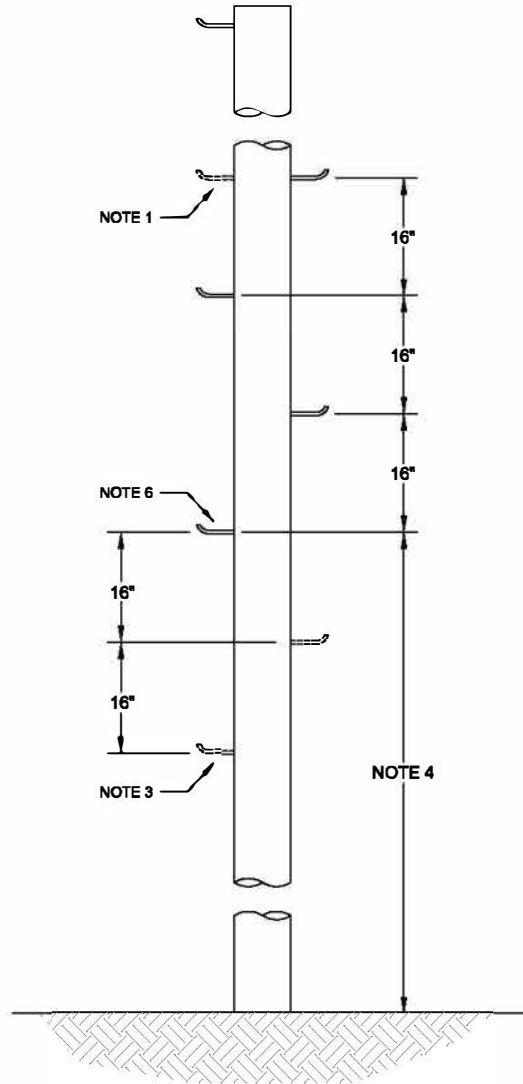

NO COMMUNICATIONS POWER SUPPLY SHALL BE MOUNTED ON POLES EXCEPT BY PERMISSION OF UTILITY.

LICENSEE'S ATTACHMENTS ON UTILITY POLES, INCLUDING METAL ATTACHMENT CLAMPS AND BOLTS, METAL CROSS ARM SUPPORTS, BOLTS AND OTHER EQUIPMENT, MUST BE ATTACHED SO AS TO MAINTAIN THE MINIMUM SEPARATIONS SPECIFIED IN THE NESC AND IN THESE DRAWINGS AND SPECIFICATIONS.

POLE STEPS MUST BE AUTHORIZED BY THE UTILITY BEFORE INSTALLATION.

**NOTES:**

1. AN ADDITIONAL STEP SHALL BE PLACED OPPOSITE A STEP LOCATED WHERE WORK IS FREQUENTLY PERFORMED.
2. WHERE POLE IS SET CLOSE TO A BUILDING WITH AN ACCESSIBLE ROOF USE DETACHABLE STEPS FROM THE ROOF LEVEL UP TO A LEVEL 8 FT. ABOVE THE ROOF.
3. USE DETACHABLE POLE STEPS WHERE STEPS ARE REQUIRED BELOW THE 8 FT. LEVEL.
4. LOCATE LOWEST HOOK POLE STEP 8 FT. ABOVE THE GROUND ON DISTRIBUTION POLES AND 8 FT. ABOVE THE GROUND ON JOINT POLES.



DATE: 01/01/19

REVISED:

## POLE STEP REQUIREMENTS

9

STANDARD  
NUMBER  
A-09



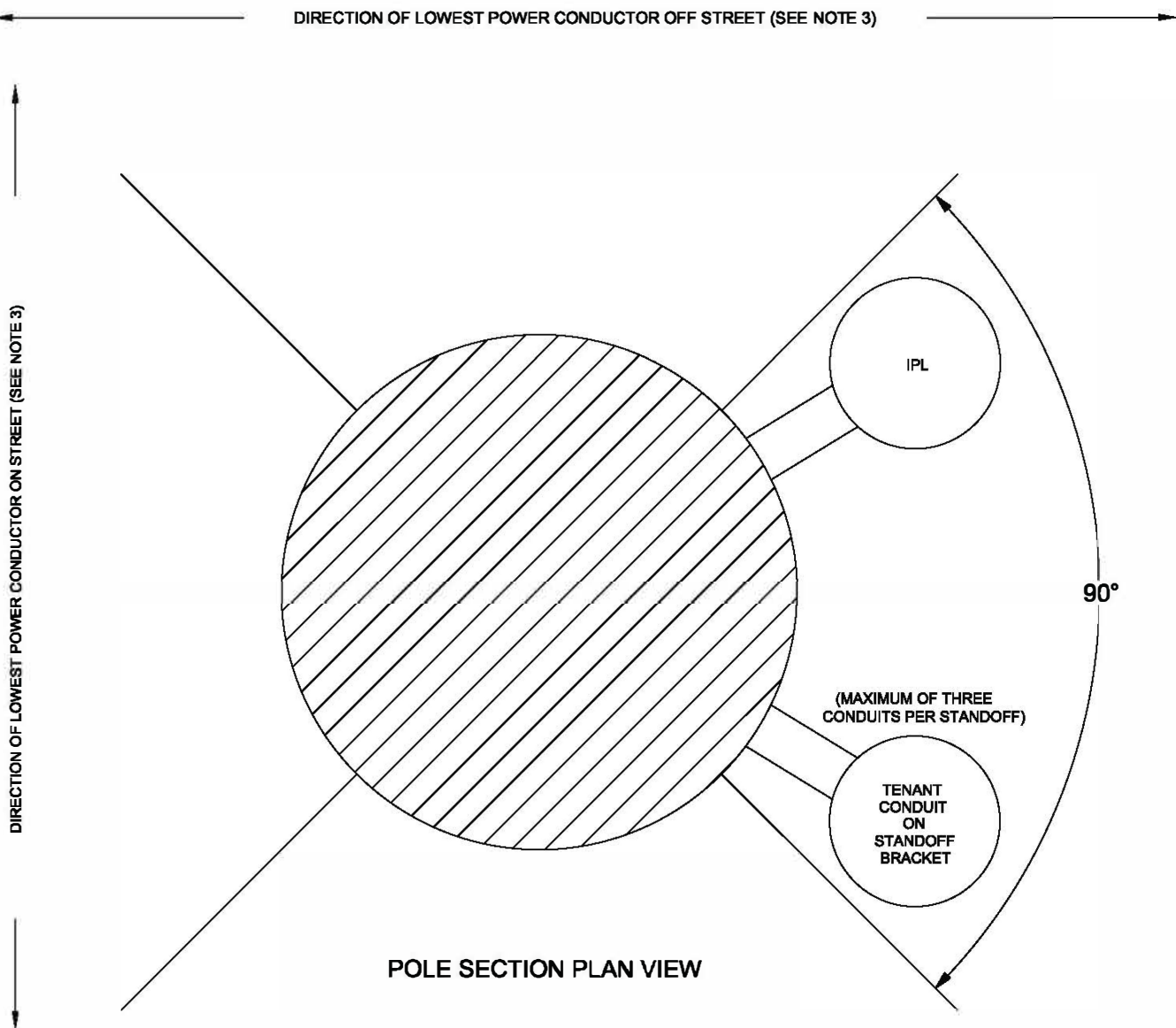

**NOTES:**

1. TENANTS CONDUIT ON STANDOFF BRACKETS MUST OCCUPY SAME 90°, OR QUARTER, OF POLE SECTION PERIPHERY AS IPL.
2. ILLUSTRATION IS AN EXAMPLE ONLY AND IS NOT INTENDED TO INDICATE A PARTICULAR ORDER OR QUANTITY OF DEVICES OR RISERS ON A POLE.
3. LOWEST POWER CONDUCTOR MAY BE SECONDARY, NEUTRAL OR PRIMARY DEPENDING ON STYLE OF CONSTRUCTION.
4. THERE SHALL BE NO MORE THAN TWO STANDOFF BRACKETS/RISERS PER POLE AS SHOWN ABOVE. ONE STANDOFF BRACKET/RISER LOCATION WILL BE RESERVED FOR FUTURE IPL FACILITIES.



DATE: 01/01/19

REVISED:

## MAXIMUM POLE RISER OCCUPANCY

STANDARD  
NUMBER  
A-10

10

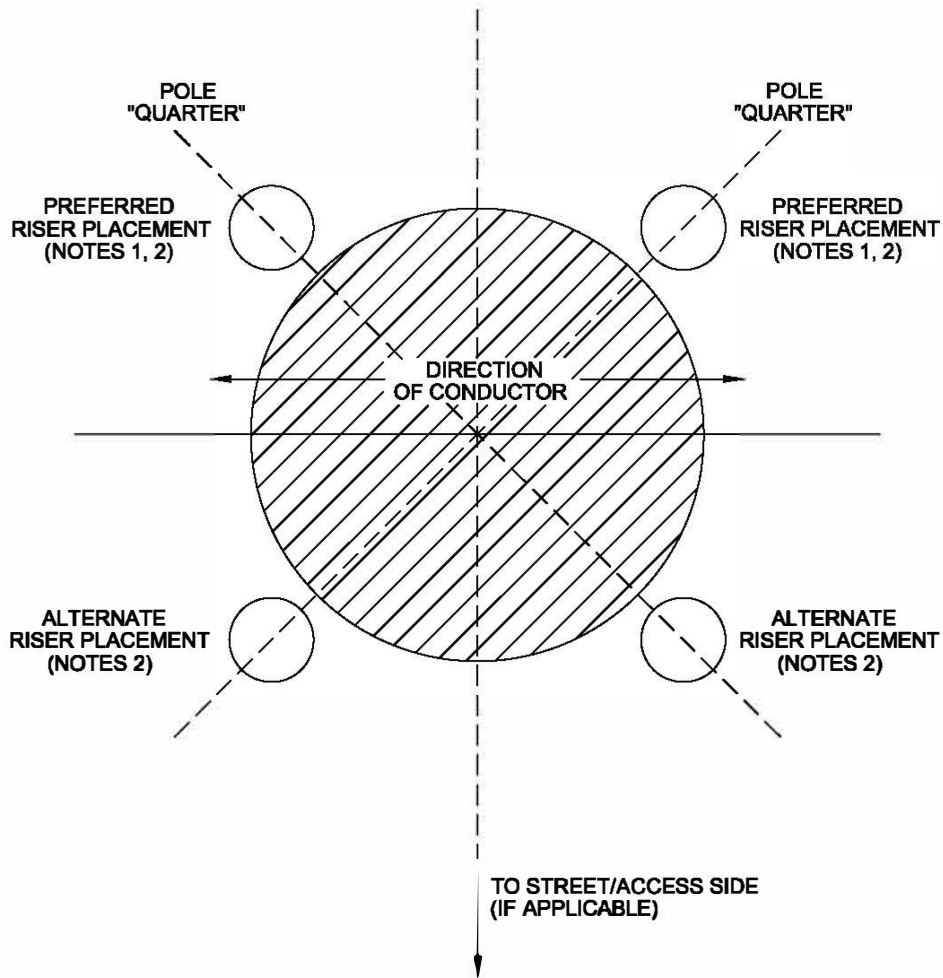

**NOTES:**

1. IF CONDUCTOR DOES NOT RUN PARALLEL TO STREET/ACCESS, PREFERRED RISER PLACEMENT IS ON THE QUARTER OF THE POLE OPPOSITE THE STREET/ACCESS SIDE.
2. IF A RISER POSITION IS BLOCKED BY EXISTING EQUIPMENT AN ALTERNATE RISER LOCATION MUST BE CHOSEN. EXISTING FOREIGN ATTACHMENTS MAY ALSO BLOCK RISER POSITIONS. IN THIS CASE, AN ALTERNATIVE RISER POSITION MUST BE CHOSEN.



DATE: 01/01/19

REVISED:

## POLE RISER ORIENTATION AND POSITIONING

STANDARD NUMBER  
A-11

11

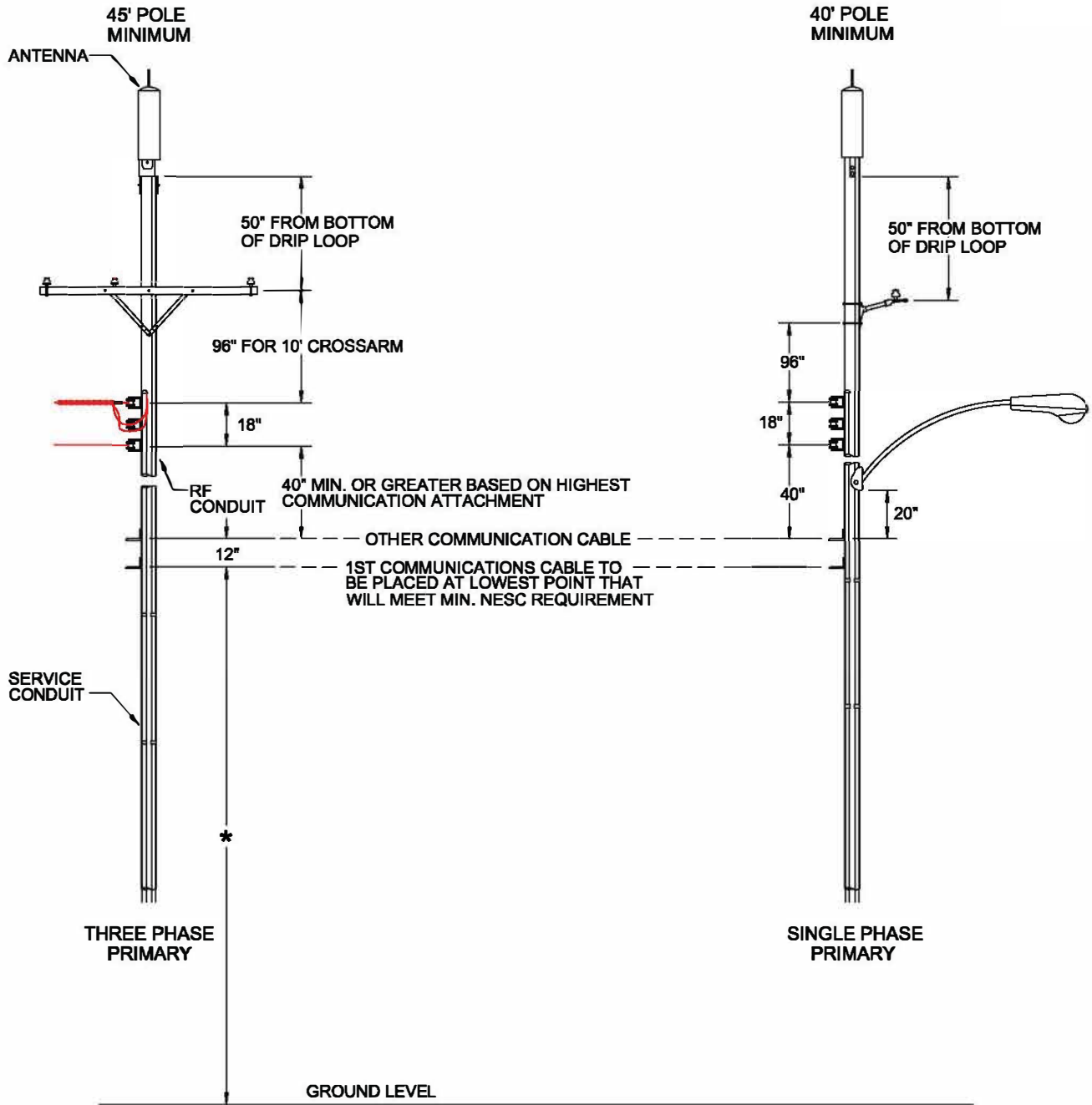

\* LOWEST COMMUNICATIONS ATTACHMENT HEIGHT IS DICTATED BY ACHIEVING MINIMUM GROUND CLEARANCE ALLOWED BY NESC AT ANY POINT IN A SPIN.



DATE: 01/01/19

REVISED:

## SPACING FOR POLE ATTACHMENTS

12

STANDARD NUMBER  
A-12

**NOTES:**

- A. STANDARD SOCKET METER INSTALLATION. SOCKET FURNISHED BY IPL DEPARTMENT AND INSTALLED BY CUSTOMER.
- B. INSULATED BUSHING FURNISHED AND INSTALLED BY CUSTOMER.
- C. TYPE 80 PVC CONDUIT AND SLIP-FITTER FURNISHED AND INSTALLED CUSTOMER. \* OCCASIONALLY THE CUSTOMER'S METER SOCKET IS LOCATED AT A LOWER ELEVATION THAN THE UTILITIES TRANSFORMER, PEDESTAL OR SECONDARY CONNECTION. OTHER MEASURES TO PROHIBIT WATER RETENTION MAY BE RECOMMENDED BY THE CUSTOMER OR CUSTOMER'S AGENT FOR APPROVAL BY THE UTILITY.
- D. DO NOT USE CENTER KNOCKOUT FOR INCOMING CONDUIT.
- E. ONLY CONTINUOUS NON-METALLIC PVC TYPE DB SCHEDULE 40 CONDUIT, FURNISHED AND INSTALLED, WITHOUT SHARP BENDS OR INDENTATIONS, BY CUSTOMER SHALL BE USED FOR SERVICE. IPL TO INSPECT BEFORE BACKFILLING.
- F. CUSTOMERS MUST PROVIDE AND INSTALL CONDUIT AND CABLE. EXCESS CABLE SHALL BE LEFT HANGING FROM WEATHERHEAD AT TOP OF RISER FOR IPL TO CONNECT TO SECONDARY.
- G. CONDUITS MAY BE INSTALLED IN JOINT TRENCH.
- H. INSTALL 2 - HOLE CLAMP ABOVE ELBOW TO STAND. LEAVE CLAMP LOOSE TO ALLOW SLIP JOINT TO WORK.
- J. COMMUNICATIONS, RF AND SERVICE CONDUITS SHALL BE Banded TO ONE SET OF STAND-OFF BRACKETS.

\*\* THE DISTANCE BETWEEN THE BOTTOM STANDOFF BRACKET AND THE SECOND STANDOFF BRACKET SHALL BE 8'.

**COMMUNICATIONS CUSTOMER EQUIPMENT**

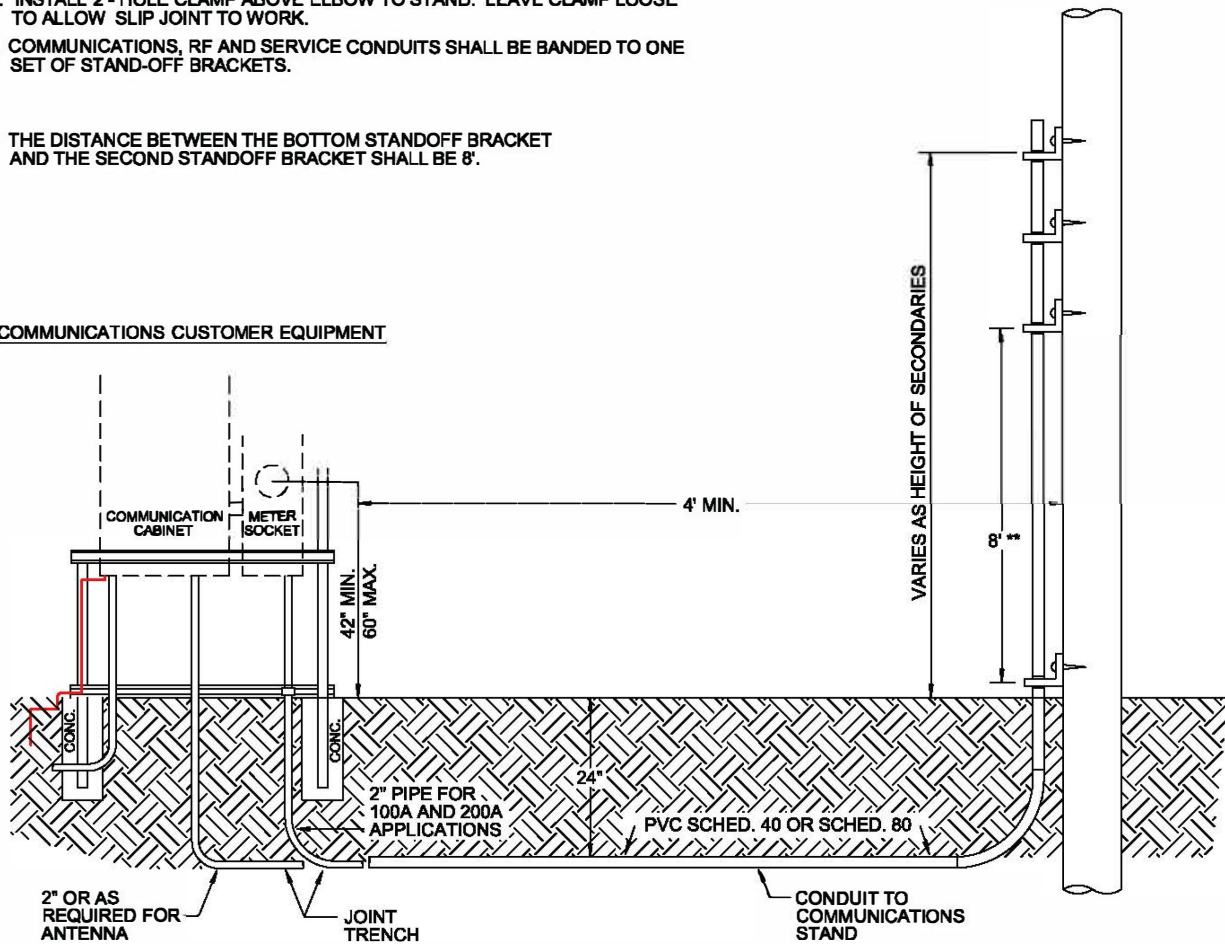

**CITY OF NIXA**  
 CHRISTIAN COUNTY, MO  
 NIXA  
 NORTHERN ILLINOIS  
 UTILITIES  
 "Count on us."  
 DATE: 01/01/19  
 REVISED:

**CABLE RISER FOR COMMUNICATION  
 TERMINAL POLES**

13  
 STANDARD  
 NUMBER  
 A-13

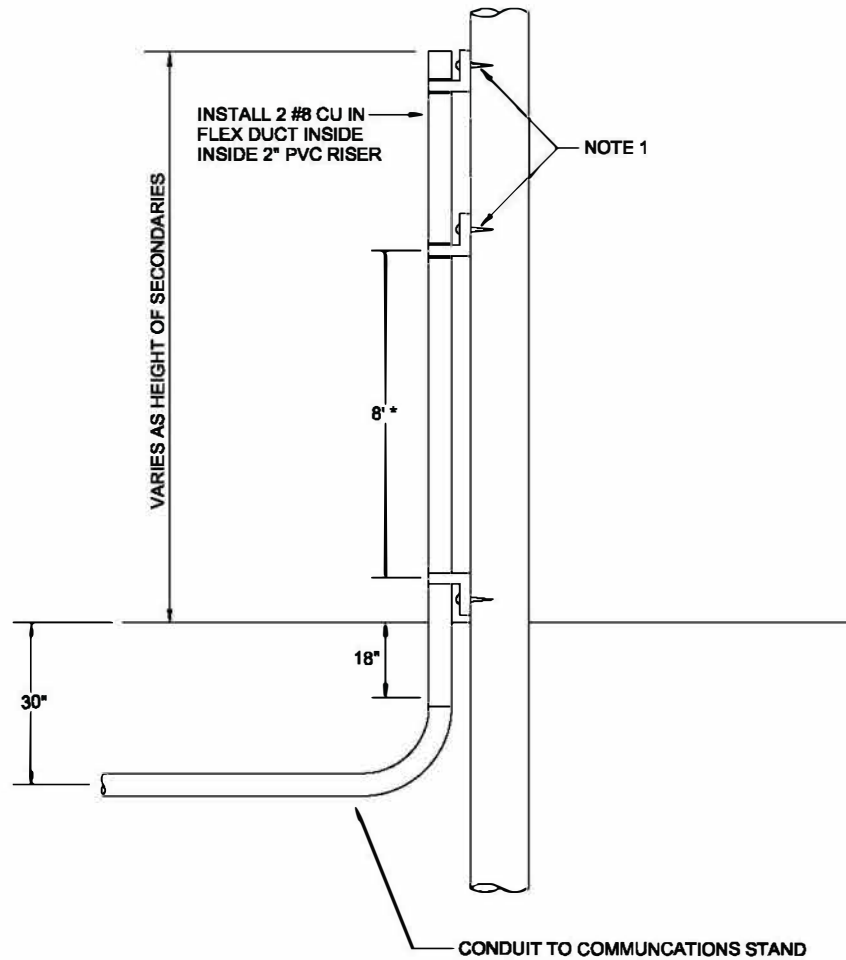

**NOTES:**

1. INSTALL PIPE AS HIGH AS CONNECTIONS WILL ALLOW. INSTALL TWO STANDOFF BRACKETS PER 10' SECTION OF PIPE ABOVE BOTTOM SECTION.
- \* THE DISTANCE BETWEEN THE BOTTOM STANDOFF BRACKET AND THE SECOND STANDOFF BRACKET SHALL BE 8'.



DATE: 01/01/19

REVISED:

## CABLE RISER FOR COMMUNICATION TERMINAL POLES

STANDARD  
NUMBER  
A-14

14



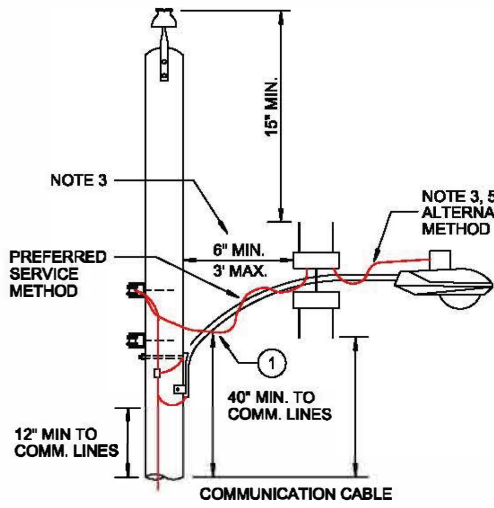

**EXISTING OPEN WIRE SECONDARY AND STREET LIGHT**

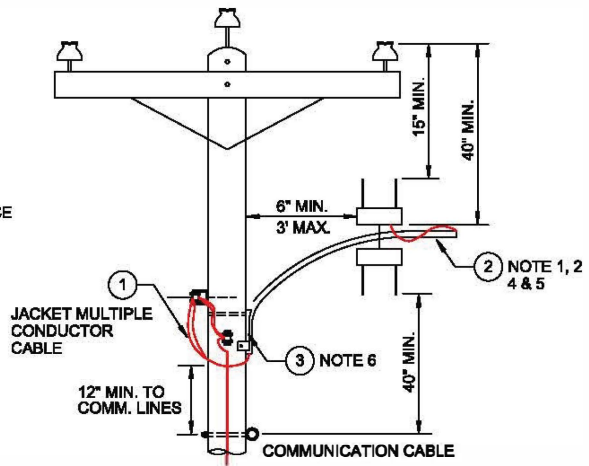

**CABLE SECONDARY - NO STREET LIGHT**

**NOTES:**

1. SUPPLY CABLE FOR PACKET ANTENNA & COMMUNICATION EQUIPMENT TO BE JACKETED MULTIPLE CONDUCTOR CABLE.
2. IF THERE IS NO EXISTING STREET LIGHT BRACKET ARM USE BRACKET ARM APPROVED BY IPL ENGINEERING. WHEN A BRACKET ARM IS INSTALLED SOLELY TO MOUNT COMMUNICATION EQUIPMENT THE JACKETED MULTIPLE CONDUCTOR CABLE SHOULD BE INSTALLED INSIDE THE BRACKET ARM.
3. MAXIMUM WEIGHT OF COMMUNICATION EQUIPMENT NOT TO EXCEED 15 LBS. WHEN INSTALLED ON EXISTING STREET LIGHT BRACKET ARM. COMMUNICATION EQUIPMENT TO BE INSTALLED A MAXIMUM 3' FROM POLE ON EXISTING BRACKET ARM.
4. CUSTOMER TO PROVIDE AND INSTALL BRACKET ARM, CONNECTORS AND JACKETED MULTIPLE CONDUCTOR CABLE AS REQUIRED.
5. TO INSTALL AND MAINTAIN EQUIPMENT WORKERS MUST BE QUALIFIED TO WORK IN SUPPLY SPACE AND USE SUPPLY WORK RULES AND METHODS.
6. BRACKET ARM SHALL BE BONDED TO POLE GROUND WITH #6 S.D. BARE COPPER CONDUCTOR.
7. ALTERNATE SERVICE METHOD FROM EXISTING STREET LIGHT MUST BE APPROVED BY IPL ENGINEERING PRIOR TO INSTALLATION.

DATE: 01/01/19

REVISED:

**ANTENNA MOUNTED IN SUPPLY SPACE WIRELESS ATTACHMENT DEVICE**

17

STANDARD NUMBER  
A-17

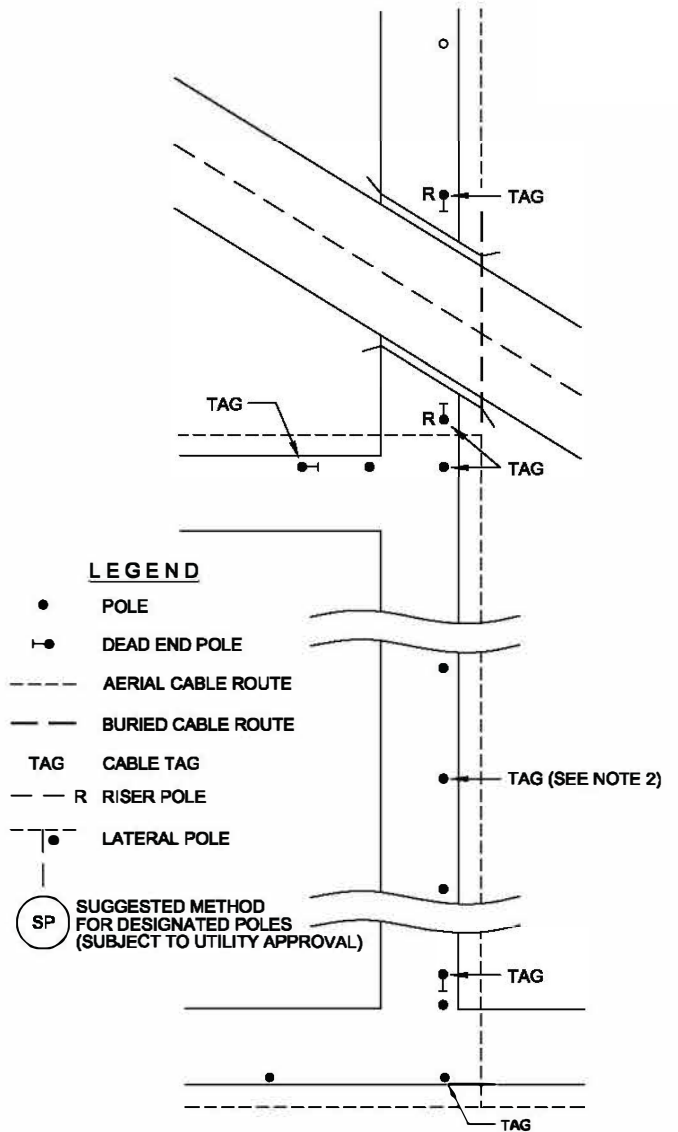
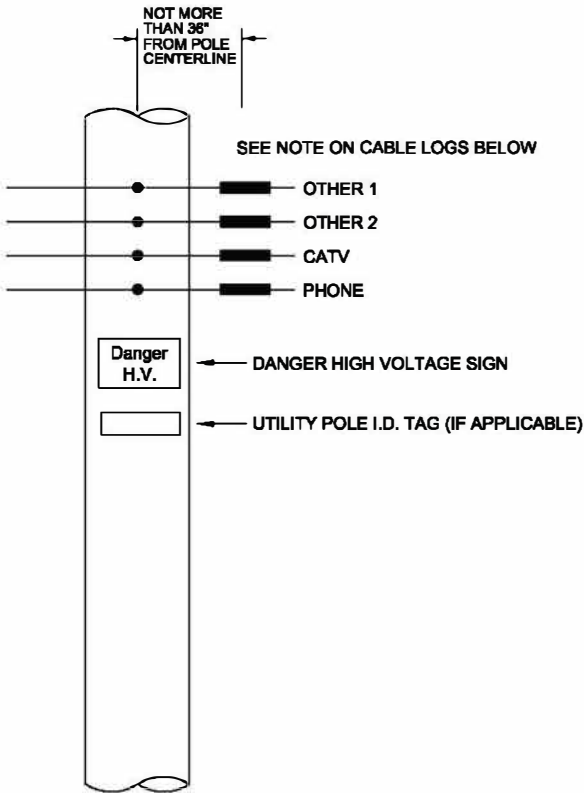

**SUGGESTED METHOD FOR DESIGNATED POLES  
(SUBJECT TO UTILITY APPROVAL)**

**CABLE OWNER  
PHONE NUMBER  
REPEAT SO INFORMATION IS VISIBLE  
FROM ALL SIDES ON THE WRAPPED TAG**

**ROLLED CABLE TAG WIDTH TO BE 5  
INCHES OR GREATER. TAG DIAMETER  
SIZED TO FIT CABLE. ALL TO BE UV  
RESISTANT MATERIAL AND PRINTING.**

**NOTES:**

1. TAGS SHOULD BE INSTALLED ON LATERAL AND DEAD END POLES AND AT THE TERMINATION POINT OF UNDERGROUND CABLE RUNS.
2. TAGS SHOULD BE INSTALLED AT LEAST EVERY 3RD POLE.
3. BURIED CABLE SIGNS SHOULD BE INSTALLED EVERY 1,000 FEET BETWEEN RISER POLES AS WELL AS ON BOTH RISER POLES.
4. TAG LOCATIONS SHOWN ABOVE ARE MINIMUM LOCATIONS. TAGS MAY BE INSTALLED AT ADDITIONAL LOCATIONS AS DEEMED NECESSARY FOR ADEQUATE IDENTIFICATION.



DATE: 01/01/19

REVISED:

# POLE TAG REQUIREMENTS

99

**STANDARD  
NUMBER  
A-99**

## APPENDIX E—Distribution Line Minimum Design Review Information and Suggested Worksheet

The following guidelines are provided, and corresponding information must be submitted with each Permit application for Pole Attachments on Utility's system. Utility may direct that certain Attachments do not require the submittal of Design Review Information. These Attachments are noted at the end of this section.

Each Permit application must include a report from a professional engineer registered to practice in the state of Missouri, and experienced in electric utility system design, or a utility-approved employee or contractor of Licensee. This report must clearly identify the proposed construction and must verify that the Attachments proposed will maintain Utility's compliance with NESC Class B construction for the loading district as outlined in the NESC Section 25.

Utility may or may not require that all of the following information be submitted at the time of the Permit application. The applicant shall have performed all required calculations and be ready to provide the detailed information below within fifteen (15) calendar days of notice. Applicant shall keep copies of the engineering data available for the length of the Agreement.

In determining compliance, the following minimum conditions shall be used in the calculations for pole strength:

1. All single-phase lines shall be assumed to have been reconducted to [code name] \_\_\_\_\_ [e.g., 4/0 AWG ACSR, code name Penguin) conductor for both phase and neutral. [If the Utility standard size conductor is larger, enter the larger size here.] If a larger conductor size exists, the larger size shall be used in the calculations.
2. All three-phase lines shall be assumed to have been to [code name] \_\_\_\_\_ (e.g., 4/0 AWG ACSR, code name Penguin) conductor for three (3) phases and neutral. [If the Utility standard size conductor is larger, enter the larger size here.] If existing conductors are larger than 4/0 AWG ACSR, the larger size shall be used in the calculations.
3. All pole lines shall assume a secondary/service conductor, installed from pole to pole, of #4/0 AWG triplex cable, with an ACSR messenger.
4. For pole strength calculations, all poles shall be as they actually exist, or be considered Class 4 for calculations.
5. All line angles or dead ends shall be guyed and anchored. Transverse pole strength shall not be assigned to attaching pole users for line angles, *i.e.*, pole

should be viewed as being void of other cables, conductors, wires, or guys and considering only the applicant's wires/cables for guying calculations.

6. Points of attachment shall be as they actually exist on the poles.
7. For a Utility-approved joint use of anchors, the Licensee shall utilize guy insulators in its guys.

Lessee shall comply with any NESC and/or Utility safety factors, whichever are more conservative, in their designs. The engineer for the Permit applicant shall provide for each application the following confirmations:

**Required permits that have been obtained** (insert n/a if not applicable):

- \_\_\_\_\_ (y/n) U.S. Corp of Engineers.
- \_\_\_\_\_ (y/n) Highway—state, county, city.
- \_\_\_\_\_ (y/n) Railroad.
- \_\_\_\_\_ (y/n) Local zoning boards, town boards, etc.
- \_\_\_\_\_ (y/n) Joint-use permits, if required.
- \_\_\_\_\_ (y/n) Notified other pole users of contacts or crossings.

**Confirm that you have:**

- (y/n) Obtained appropriate franchise(s).
- (y/n) Obtained pole/anchor easements from landowners.
- (y/n) Obtained crossing and overhang permits.
- (y/n) Obtained permit to survey R/W.
- (y/n) Completed State of Missouri Department of Transportation requirements.
- (y/n) Placed permit number on plans.
- (y/n) Complied with Missouri Underground Facility Location requirements.
- (y/n) Included sag/tension data on proposed cable.

Calculations are based upon the latest edition of the NESC and the latest editions of the requirements of the state of Missouri,

It is Licensee's responsibility to obtain all necessary permits and provide the Utility with a copy of each.

The engineer for the Permit applicant shall provide for each Pole(s) the following information:

Project ID

Pole number \_\_\_\_\_ [if pole tag missing, contact Utility]  
 Pole class \_\_\_\_\_ [existing—*i.e.*, 4, 3, 2...]  
 Pole size \_\_\_\_\_ [existing—*i.e.*, 35, 40...]  
 Pole type \_\_\_\_\_ [Southern Yellow Pine, Douglas Fir...]  
 Pole fore span \_\_\_\_\_ [feet]  
 Pole fore span direction \_\_\_\_\_ [degrees from Magnetic North]  
 Pole back span \_\_\_\_\_ [feet]  
 Pole back span direction \_\_\_\_\_ [degrees from Magnetic North]  
 Calculated bending  
 moment at ground level \_\_\_\_\_ [ft-lbs]

**Existing:**

Power phase condition \_\_\_\_\_ quantity of \_\_\_\_\_ AWG/MCM  
 \_\_\_\_\_ CU/AA/ACSR @ \_\_\_\_\_ feet above ground line  
 Power neutral condition \_\_\_\_\_ quantity of \_\_\_\_\_ AWG/MCM  
 \_\_\_\_\_ CU/AA/ACSR @ \_\_\_\_\_ feet above ground line  
 Power sec condition \_\_\_\_\_ quantity of \_\_\_\_\_ AWG/MCM  
 \_\_\_\_\_ CU/AA/ACSR @ \_\_\_\_\_ feet above ground line  
 Power service #1 \_\_\_\_\_ qty of \_\_\_\_\_ size @ \_\_\_\_\_ ft above ground line  
 @ \_\_\_\_\_ ° \_\_\_\_\_ , \_\_\_\_\_ ”  
 Power service #2 \_\_\_\_\_ qty of \_\_\_\_\_ size @ \_\_\_\_\_ ft above ground line  
 @ \_\_\_\_\_ ° \_\_\_\_\_ , \_\_\_\_\_ ”  
 Power service #3 \_\_\_\_\_ qty of \_\_\_\_\_ size @ \_\_\_\_\_ ft above ground line  
 @ \_\_\_\_\_ ° \_\_\_\_\_ , \_\_\_\_\_ ”  
 Telco #1 cables \_\_\_\_\_ qty of \_\_\_\_\_ dia @ \_\_\_\_\_ ft above ground line  
 Telco service #1 \_\_\_\_\_ qty of \_\_\_\_\_ size @ \_\_\_\_\_ ft above ground line  
 @ \_\_\_\_\_ ° \_\_\_\_\_ , \_\_\_\_\_ ”  
 Telco service #2 \_\_\_\_\_ qty of \_\_\_\_\_ size @ \_\_\_\_\_ ft above ground line  
 @ \_\_\_\_\_ ° \_\_\_\_\_ , \_\_\_\_\_ ”  
 CATV #2 cables \_\_\_\_\_ qty of \_\_\_\_\_ dia @ \_\_\_\_\_ ft above ground line  
 CATV service #1 \_\_\_\_\_ qty of \_\_\_\_\_ size @ \_\_\_\_\_ ft above ground line  
 @ \_\_\_\_\_ ° \_\_\_\_\_ , \_\_\_\_\_ ”  
 CATV service #2 \_\_\_\_\_ qty of \_\_\_\_\_ size @ \_\_\_\_\_ ft above ground line  
 @ \_\_\_\_\_ ° \_\_\_\_\_ , \_\_\_\_\_ ”



User #3 cables \_\_\_\_\_ qty of \_\_\_\_\_ dia @ \_\_\_\_\_ ft above ground line  
User #4 cables \_\_\_\_\_ qty of \_\_\_\_\_ dia @ \_\_\_\_\_ ft above ground line  
User #5 cables \_\_\_\_\_ qty of \_\_\_\_\_ dia @ \_\_\_\_\_ ft above ground line  
User #6 cables \_\_\_\_\_ qty of \_\_\_\_\_ dia @ \_\_\_\_\_ ft above ground line

Equipment #1 type \_\_\_\_\_ qty of \_\_\_\_\_ size @ \_\_\_\_\_ ft above ground line

Equipment #1 type \_\_\_\_\_ qty of \_\_\_\_\_ size @ \_\_\_\_\_ ft above ground line

Equipment #1 type \_\_\_\_\_ qty of \_\_\_\_\_ size @ \_\_\_\_\_ ft above ground line

Equipment #1 type \_\_\_\_\_ qty of \_\_\_\_\_ size @ \_\_\_\_\_ ft above ground line

**Proposed:**

Proposed cables \_\_\_\_\_ qty of \_\_\_\_\_ dia @ \_\_\_\_\_ ft above ground line

fore and back span direction \_\_\_\_\_ ° \_\_\_\_\_ ' \_\_\_\_\_ ", \_\_\_\_\_ ° \_\_\_\_\_ ' \_\_\_\_\_ "

Proposed cables \_\_\_\_\_ qty of \_\_\_\_\_ dia @ \_\_\_\_\_ ft above ground line

fore and back span direction \_\_\_\_\_ ° \_\_\_\_\_ ' \_\_\_\_\_ ", \_\_\_\_\_ ° \_\_\_\_\_ ' \_\_\_\_\_ "

Equipment #1 type \_\_\_\_\_ qty of \_\_\_\_\_ size @ \_\_\_\_\_ ft above ground line

Equipment #2 type \_\_\_\_\_ qty of \_\_\_\_\_ size @ \_\_\_\_\_ ft above ground line

AGL = Above Ground Level

The minimum vertical clearance under all loading conditions measured from the proposed cable to ground level on each conductor span shall be stated above. Variations in topography resulting in ground elevation changes shall be considered when stating the minimum vertical clearance within a given span.

Calculated pole bending moment at ground level: \_\_\_\_\_ [ft-lbs]

Pole breaking bending moment at ground level: \_\_\_\_\_ [ft-lbs]

Calculated transverse safety factor: \_\_\_\_\_ [ratio should be greater than 1.00]

Proposed loading data [provide similar data for each cable proposed]:

A. Weight data (cable and messenger)—

1. Vertical weight, bare = \_\_\_\_\_ [#ft]

B. Tension data (final tensions on messenger)—

1. NESC maximum load for area of construction: \_\_\_\_\_ [lbs]
2. 60° F, NO wind: \_\_\_\_\_ [lbs]

Permit applicant's engineer shall provide for each transverse guy, or dead end to which guys and/or anchors are attached, the following information:

Pole number \_\_\_\_\_

Calculated cable messenger tension under  
NESC maximum loading conditions \_\_\_\_\_ [lbs]

**If connection is:**

A dead end, is it a single or double? \_\_\_\_\_ [S, D]

A change in tension, what is change? \_\_\_\_\_ [lbs]

A line angle, what is angle change? \_\_\_\_\_ [degrees]

What is tension change at angle? \_\_\_\_\_ [lbs]

**For each dead end:**

Point of attachment for guy hook \_\_\_\_\_ [feet AGL]

Anchor distance from pole \_\_\_\_\_ [feet]

Calculated guy tension \_\_\_\_\_ [lbs]

Rated guy working strength \_\_\_\_\_ [lbs]

**For each change in tension:**

Point of attachment for guy hook \_\_\_\_\_ [feet AGL]

Anchor distance from pole \_\_\_\_\_ [feet]

Calculated guy tension \_\_\_\_\_ [lbs]

Rated guy working strength \_\_\_\_\_ [lbs]

**For each line angle:**

Point of attachment for guy hook \_\_\_\_\_ [feet AGL]

Anchor distance from pole \_\_\_\_\_ [feet]

Calculated guy tension \_\_\_\_\_ [lbs]

Rated guy working strength \_\_\_\_\_ [lbs]

**For each anchor:**

Anchor distance to nearest anchor \_\_\_\_\_ [feet]

Calculated anchor tension \_\_\_\_\_ [lbs]

Rated anchor strength \_\_\_\_\_ [lbs]  
Soil composition \_\_\_\_\_ [sandy, loam, clay, rock]

**For each dead end:**

Point of attachment for guy hook \_\_\_\_\_ [feet AGL]  
Anchor distance from pole \_\_\_\_\_ [feet]  
Calculated guy tension \_\_\_\_\_ [lbs]  
Rated guy working strength \_\_\_\_\_ [lbs]

**For each change in tension:**

Point of attachment for guy hook \_\_\_\_\_ [feet AGL]  
Anchor distance from pole \_\_\_\_\_ [feet]  
Calculated guy tension \_\_\_\_\_ [lbs]  
Rated guy working strength \_\_\_\_\_ [lbs]

**For each line angle:**

Point of attachment for guy hook \_\_\_\_\_ [feet AGL]  
Anchor distance from pole \_\_\_\_\_ [feet]  
Calculated guy tension \_\_\_\_\_ [lbs]  
Rated guy working strength \_\_\_\_\_ [lbs]

**For each anchor:**

Anchor distance to nearest anchor \_\_\_\_\_ [feet]  
Calculated anchor tension \_\_\_\_\_ [lbs]  
Rated anchor strength \_\_\_\_\_ [lbs]  
Soil composition \_\_\_\_\_ [sandy, loam, clay, rock]

# APPENDIX F—Field Data Summary Sheet Instructions

| <u>Column</u>   | <u>Instructions</u>   |
|---|---|
| <b>Utility Pole Number</b> .....                                | If a Pole stencil is not in place, it may be left for Utility if the accompanying sketch is adequate to determine the Location.                           |
| <b>Communication Company's<br/>Plan Sheet Pole Number</b> ..... | This must correspond with the plan sheet or Pole Sketch Pole identification number.   |
| <b>Pole Height and Class</b> .....                              | List the present Pole height and class and list the proposed Pole height and class if it is necessary for Utility to replace the Pole for clearance, etc. |
| <b>Guy Attachments</b> .....                                    | All unbalanced loading on Poles must be guyed. Attachments to Utility's anchors will not be allowed.  |
| <b>Attachment Height</b> .....                                  | Communications Company attachment height above ground level. List guy lead in feet.   |
| <b>Inches Below Utility</b> .....                               | The number of inches Communications Company is to be attached below Utility while maintaining clearance as required in Item #4.                           |
| <b>Span Length</b> .....  | List the back span length for each attachment.  |
| <b>Inches Sag</b> .....   | List the messenger sag for the design listed on the cover sheet at 60 degrees Fahrenheit.   |
| <b>Ground Clearance</b> .....                                   | List the ground clearance at the low point of the back span. Must not be less than the National Electrical Safety Code (latest edition).                  |